

DESARROLLO AGROECOLÓGICO

MODELO AGROECOLÓGICO A PARTIR DE PROTOTIPOS SUSTENTABLES DE VIVIENDA RURAL PRODUCTIVA EN EL MUNICIPIO DE DUITAMA BOYACÁ

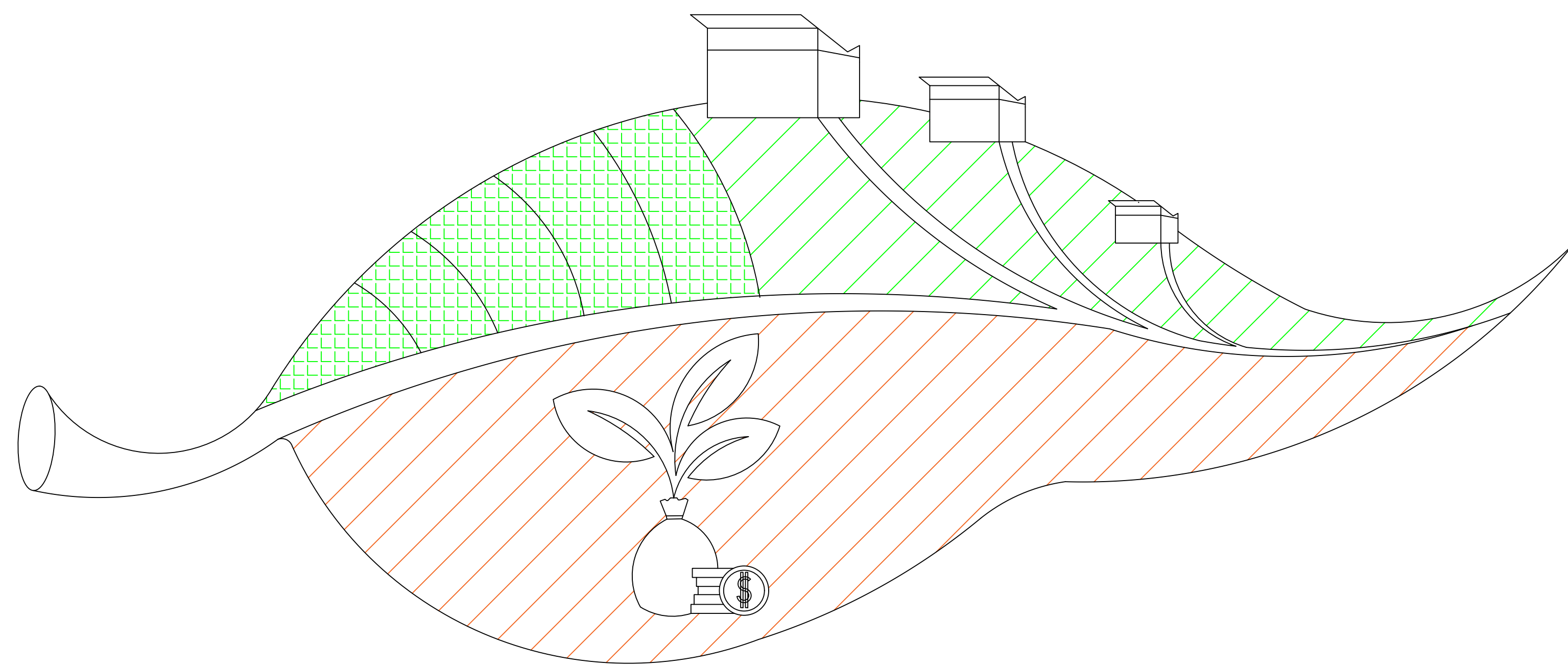

INDICE DE CONTENIDO PLANIMETRIA

U -001	<u>INDICE DE CONTENIDO PLANIMETRIA</u>
U -002	<u>LOCALIZACIÓN</u>
U -003	<u>3 ESTRUCTURAS DE LA UNIDAD DE PLANEAMIENTO RURAL</u>
U -004	<u>UNIDAD DE PLANEAMIENTO RURAL - CUADRO DE AREAS</u>
A -001	<u>PLANTA ARQUITECTONICA VIVIENDA MODULAR</u>
A -002	<u>PLANTA ARQUITECTONICA CORRALES</u>
A -003	<u>PLANTA ARQUITECTONICA CUBIERTAS</u>
E -001	<u>PLANTA ESTRUCTURAL EJES Y CIMIENTOS</u>
E -002	<u>PLACA ESTRUCTURA CUBIERTA</u>
F -001	<u>FACHADAS</u>
B -001	<u>CORTES - LONGITUDINALES Y TRANSVERSALES VIVIENDA PROGRESIVA</u>
P -001	<u>INSTALACIONES ELECTRICAS, HIDRAULICAS</u>
P -001	<u>INSTALACION SUMINISTRO DE BIOGAS</u>
D -001	<u>DETALLES</u>

DE:	PLANO N°	REVISION
PLANCHA N°	1	
FACULTAD DE ARQUITECTURA		
PROYECTO: MODELO AGROECOLÓGICO A PARTIR DE PROTOTIPOS SUSTENTABLES DE VIVIENDA RURAL PRODUCTIVA EN EL MUNICIPIO DE DUITAMA BOYACÁ		
CONVENIONES INDICE DE CONTENIDO DEL PROYECTO		
CONTIENE: INDICE DE CONTENIDO DEL PROYECTO		
LOCALIZACIÓN: 		
ESCALA	FECHA 02/12/2022	
NOTA	FIRMA TUTOR	
PLANCHA N° 1	PLANCHA N°	
REVISION	PLANO N° U - 001	PLANCHA N° 1
		DE: 14

COLOMBIA

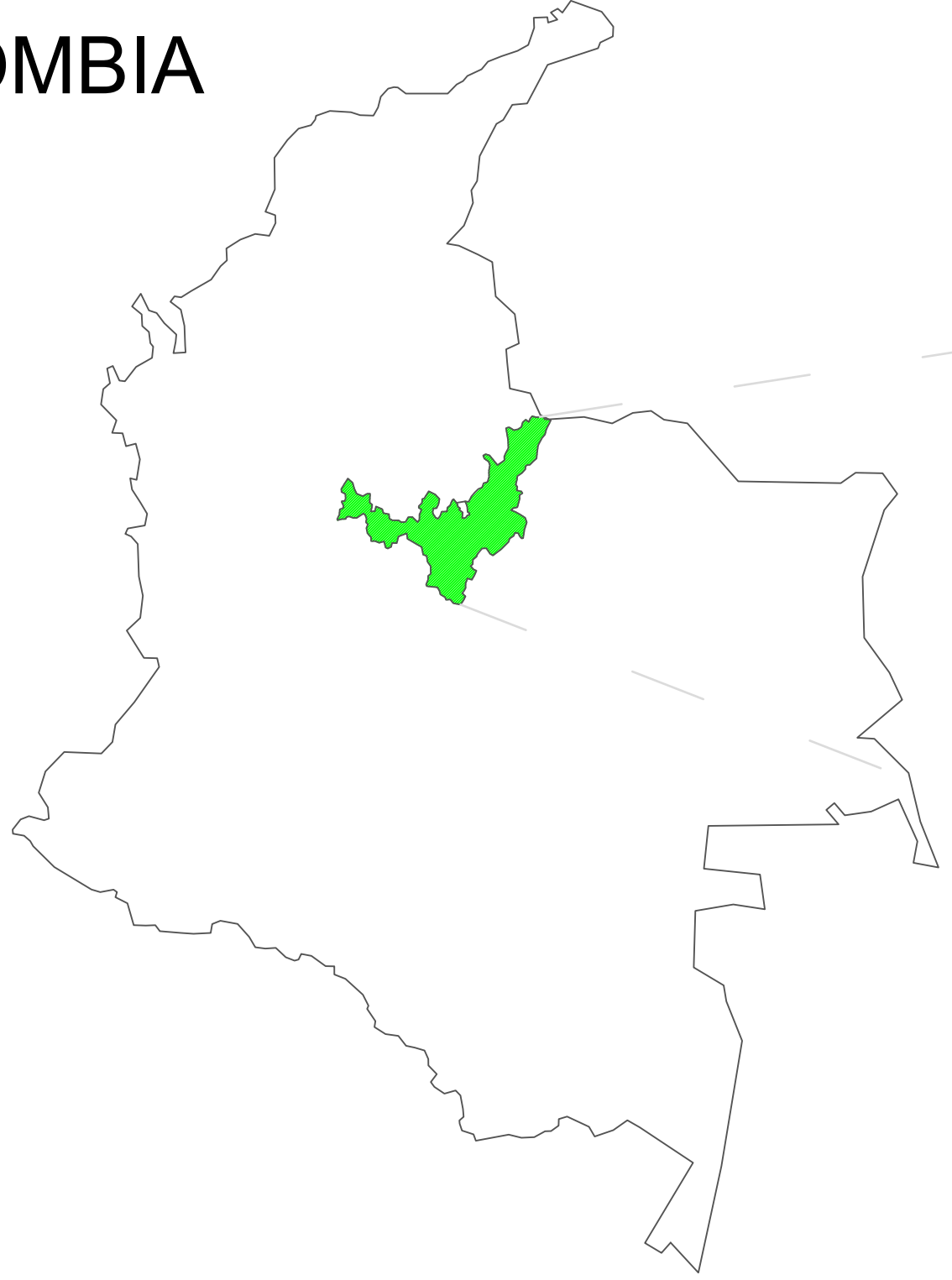

BOYACÁ

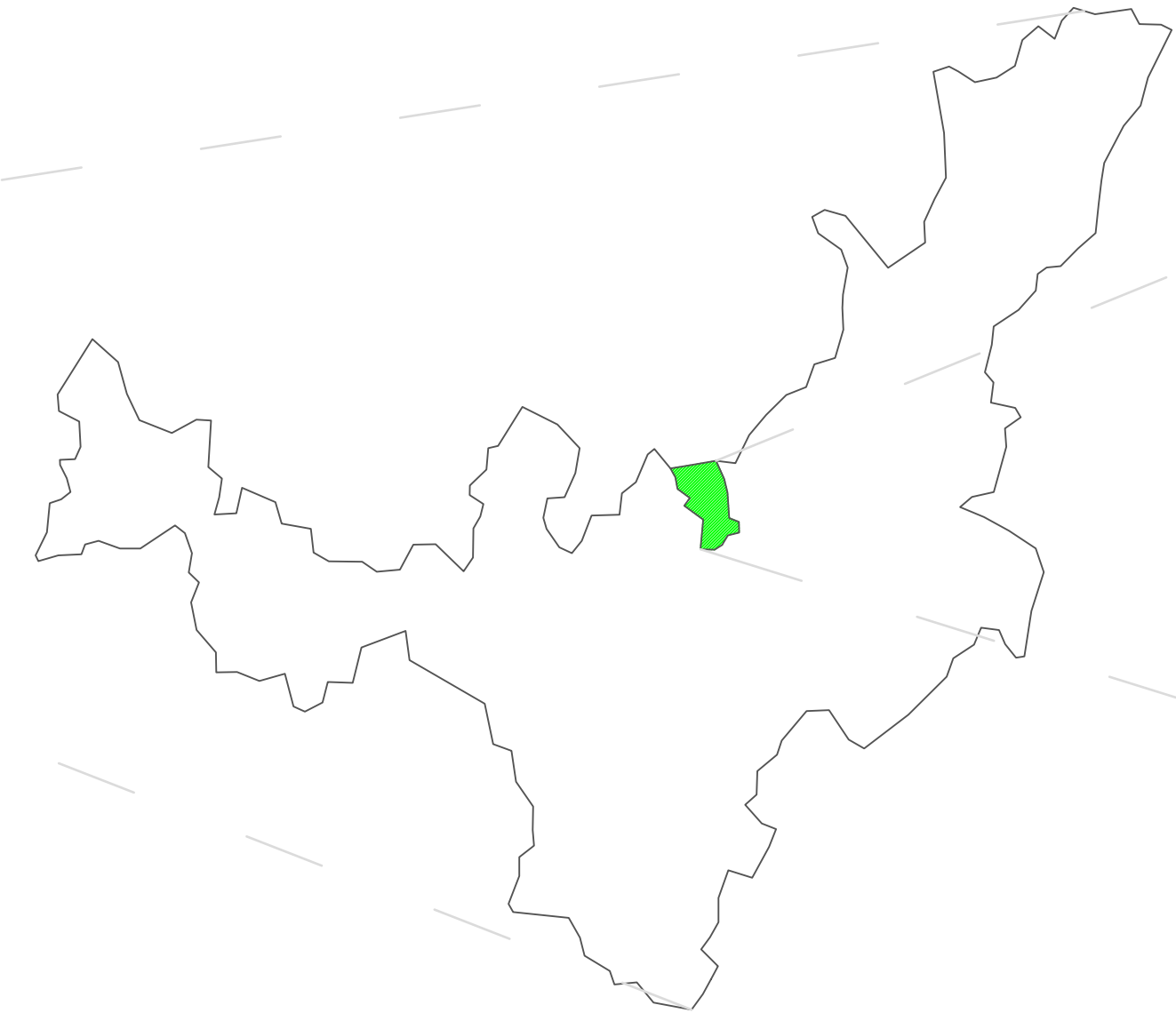

DUITAMA

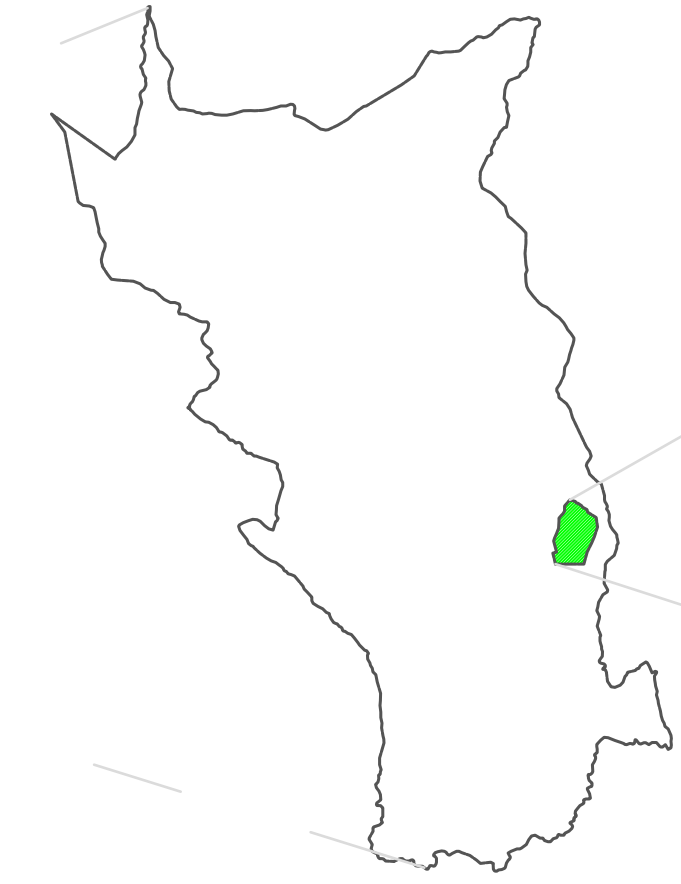

UPR

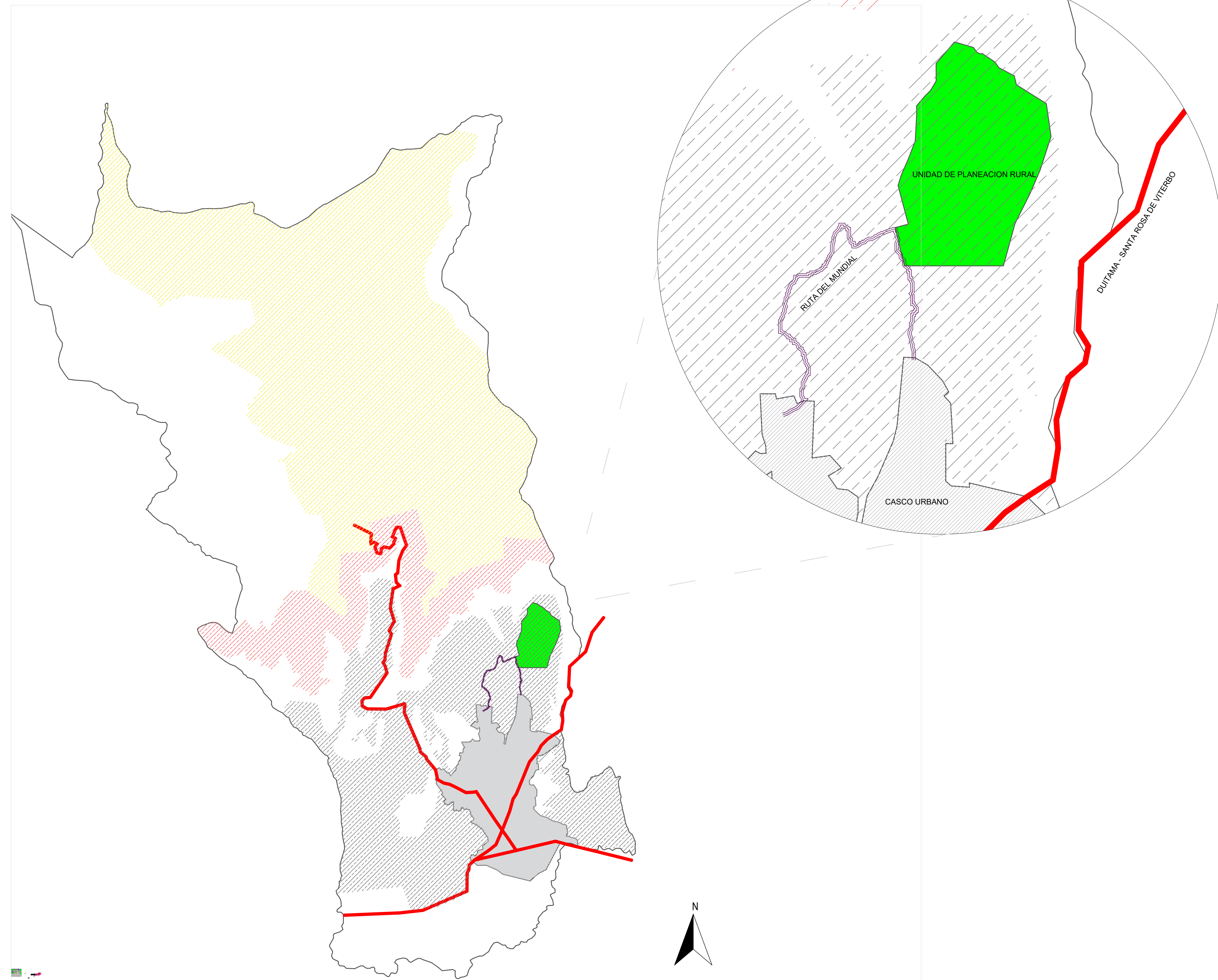
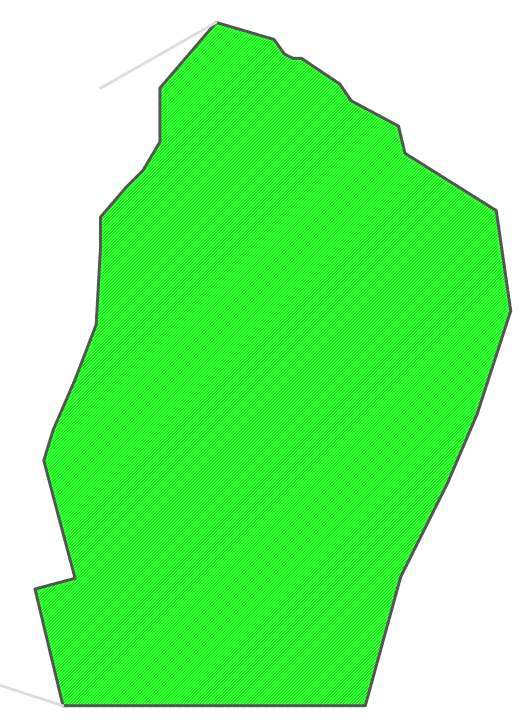

DE:	PLANO N°	REVISION
PLANCHA N°	PLANO N°	REVISION
FACULTAD DE ARQUITECTURA		
PROYECTO:		
MODELO AGROECOLÓGICO A PARTIR DE PROTOTIPOS SUSTENTABLES DE VIVIENDA RURAL PRODUCTIVA EN EL MUNICIPIO DE DUITAMA BOYACÁ		
CONVERSIONES		
	UBICACION PROYECTO	
	AGROPECUARIO INTENSIVO	
	AMORTIGUAMIENTO PARAMO	
	PROTECCION A NACIMIENTO DE AGUA	
	VIA PRINCIPALES	
	VIAS SECUNDARIAS	
CONTIENE:		
UBICACION DEL PROYECTO, EN EL DEPARTAMENTO DE BOYACA, CIUDAD DUITAMA BOYACA, VEREDA LA FLORIDA		
LOCALIZACIÓN:		
ESCALA	FECHA	
	02/12/2022	
NOTA	FIRMA TUTOR	
PLANCHA N°	PLANCHA N°	
2		
REVISION	PLANO N°	PLANCHA N°
	U - 002	2
		DE:
		14

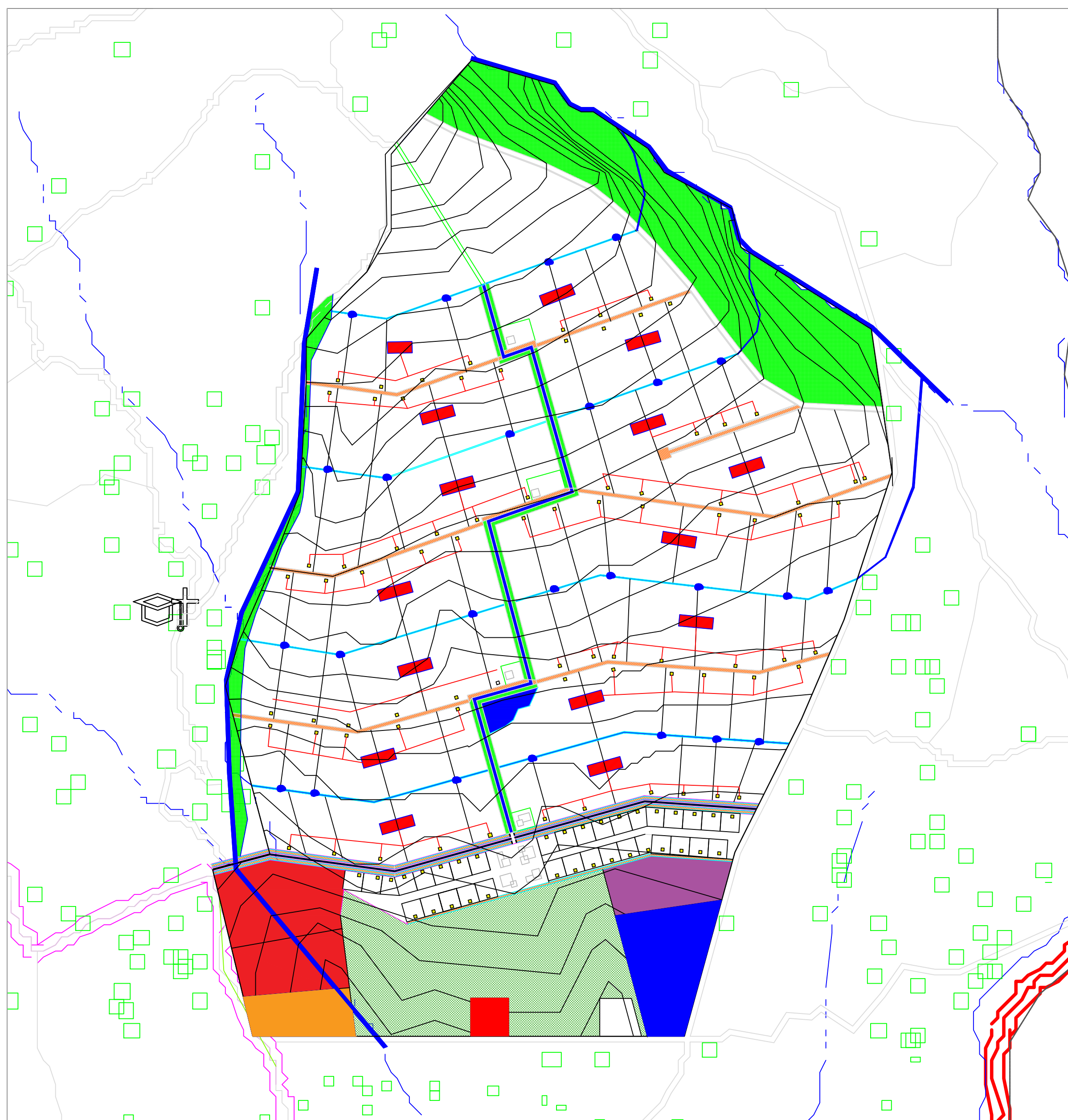

ESTRUCTURA FUNCIONAL Y DE SERVICIOS

SISTEMA DE MOVILIDAD
 VIA NACIONAL
 VIA SECUNDARIAS
 PROMUESTA VIAL
 ALAMEDA

SISTEMA DE EQUIPAMENTOS
 EQUIPAMENTOS EDUCACION TECNICA
 EQUIPAMIENTO VETERINARIO
 EQUIPAMIENTO PARA ALQUILER DE MAQUINARIA
 EQUIPAMIENTO DEPORTIVO

BIOGAS
 RED DE DISTRIBUCION DEL BIOGAS
 PARTIENDO DESDE EL BIODIGESTOR

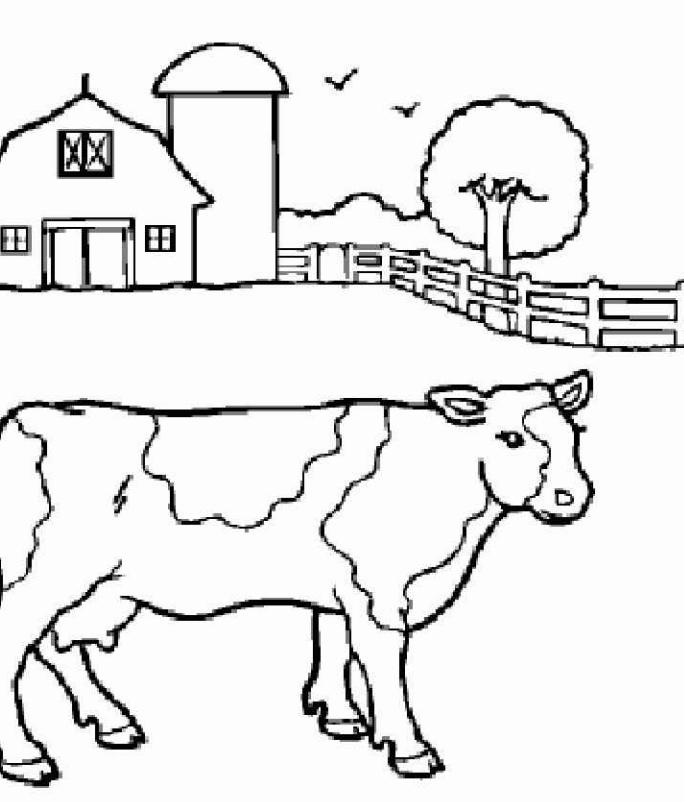
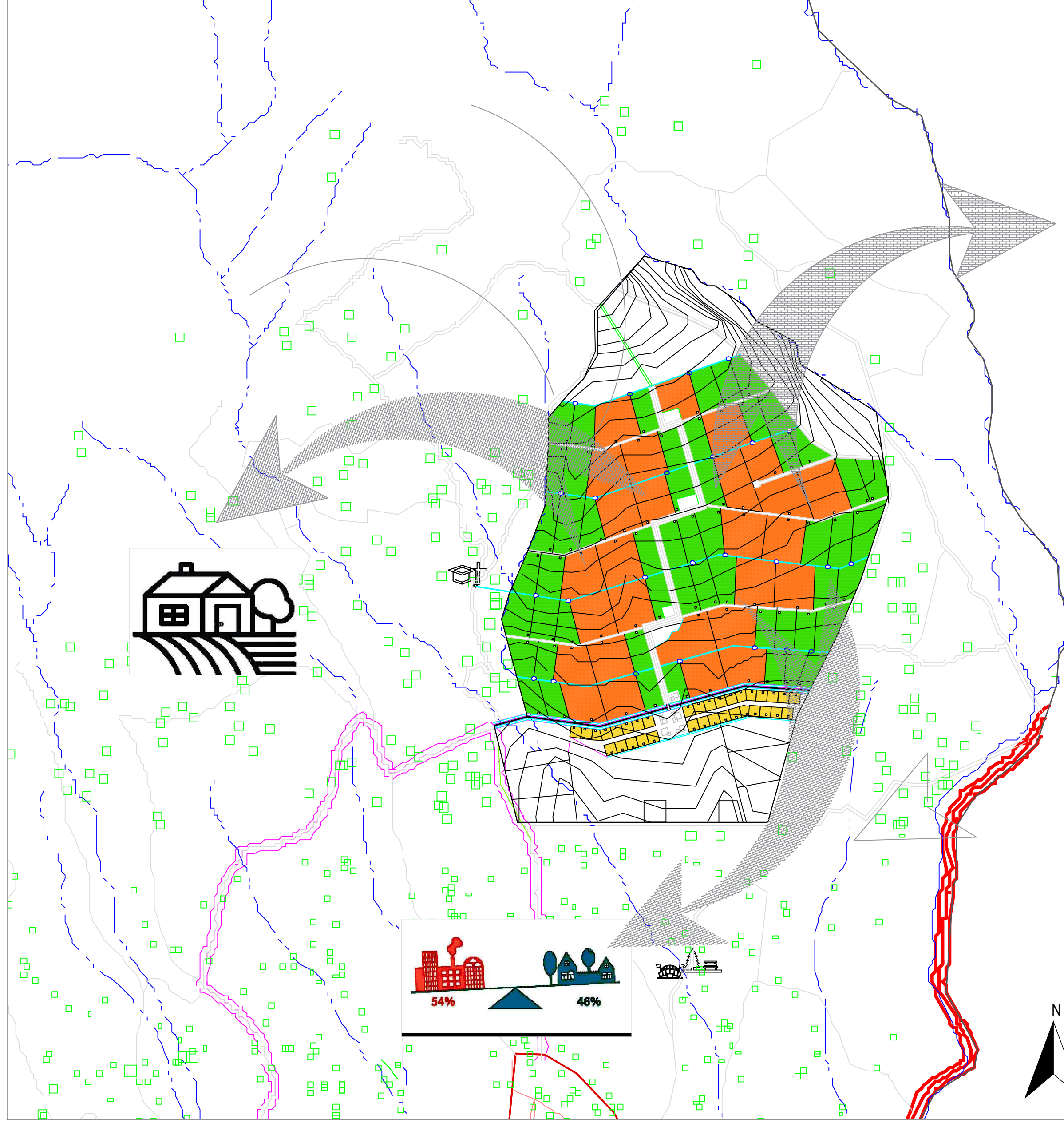
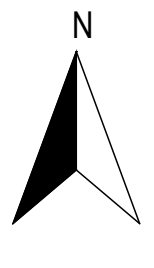

ESTRUCTURA SOCIOECONOMICA

POBLACION 100% CAMPESINA
 MISTO ENTRE CAMPO Y CIUDAD
 POBLACION QUE RESIDE EN EL CAMPO PERO
 TRABAJA EN LA CIUDAD

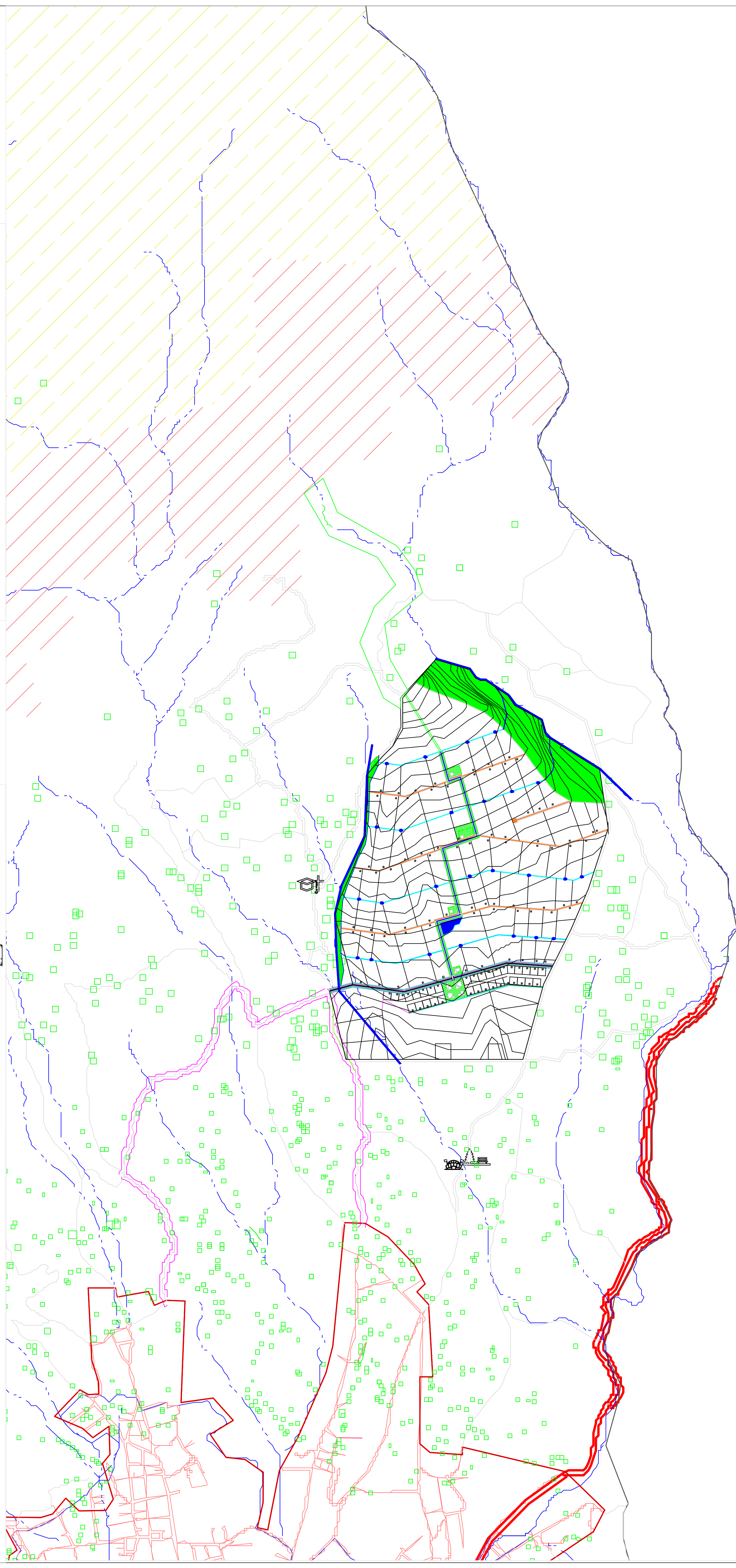
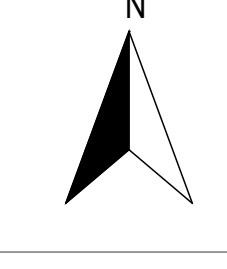

ESTRUCTURA AMBIENTAL

BOSQUE NATIVO
 AGROPECUARIO INTENSIVO
 AMORTIGUAMIENTO PARAMO
 PROTECCION A NACIMIENTO DE AGUA
 ESPACIO PUBLICO

VIA PRINCIPALES
 VIAS SECUNDARIAS
 VIAS SECUNDARIAS

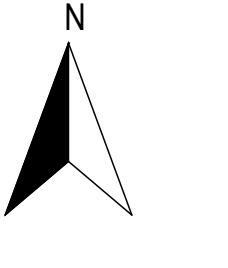

DE:	PLANO N°	REVISION
PLANCHA N°	PLANO N°	
FACULTAD DE ARQUITECTURA		
PROYECTO: MODELO AGROECOLOGICO A PARTIR DE PROTOTIPOS SUSTENTABLES DE VIVIENDA RURAL PRODUCTIVA EN EL MUNICIPIO DE DUITAMA BOYACA		
CONVENIONES		
CONTIENE: LAS 3 ESTRUCTURAS DE LA UNIDAD DE PLANEACION RURAL, ESTRUCTURA FUNCIONAL Y DE SERVICIOS, ESTRUCTURA AMBIENTAL, ESTRUCTURA SOCIOECONOMICA		
LOCALIZACIÓN: 		
ESCALA	FECHA	
	02/12/2022	
NOTA	FIRMA TUTOR	
PLANCHA N°	PLANCHA N°	
3		
REVISION	PLANO N°	PLANCHA N°
	U - 003	3
		DE:
		14

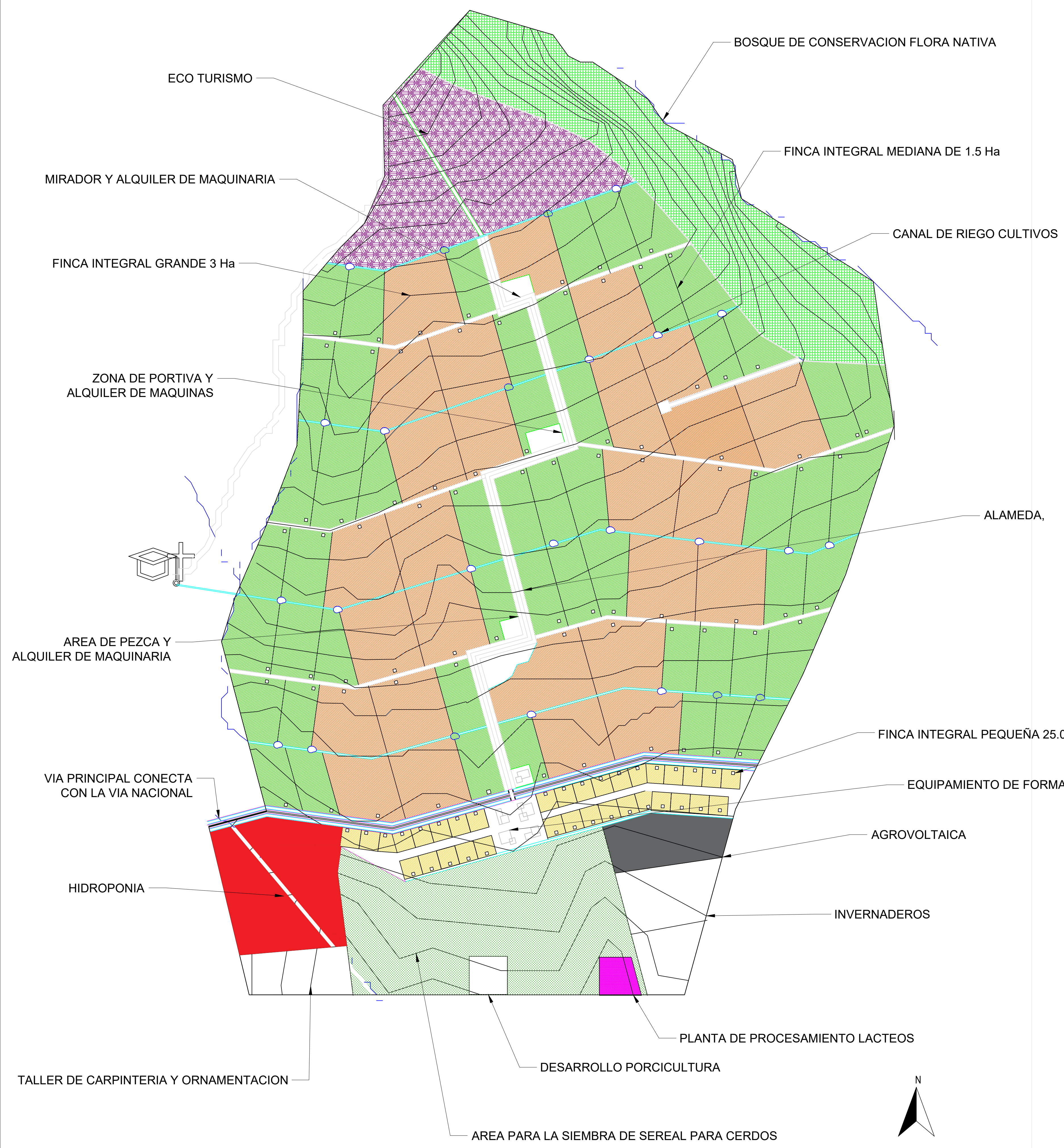

SESIONES DE LAS UNIDADES DE ACTUACION RURAL

325 Ha	ÁREA BRUTA
51 Ha	CONSERVACION Y PROTECCION AMBIENTAL
5 Ha	EQUIPAMIENTOS Y ESPACIO PUBLICO
3.5 Ha	VIAS
51 Ha	AREA ECO INDUSTRIAL

214.5 Ha	AREA NETA
----------	-----------



DE:	PLANO N°	REVISION
PLANCHA N°	PLANO N°	PLANCHA N°
FACULTAD DE ARQUITECTURA		
PROYECTO:		
MODELO AGROECOLÓGICO A PARTIR DE PROTOTIPOS SUSTENTABLES DE VIVIENDA RURAL PRODUCTIVA EN EL MUNICIPIO DE DUITAMA BOYACÁ		
CONVERSIONES		
CONTIENE:		
UNIDAD DE PLANEAMIENTO RURAL - CUADRO DE AREAS		
LOCALIZACIÓN:		
ESCALA	FECHA	
	02/12/2022	
NOTA	FIRMA TUTOR	
PLANCHA N°	PLANCHA N°	
4		
REVISION	PLANO N°	PLANCHA N°
	U - 004	4
		DE:
		14



A PLANO ARQUITECTONICO
ESC:1:25

DE:	PLANO N°	REVISION
PLANCHA N°	5	
FACULTAD DE ARQUITECTURA		
PROYECTO:		
MODELO AGROECOLOGICO A PARTIR DE PROTOTIPOS SUSTENTABLES DE VIVIENDA RURAL PRODUCTIVA EN EL MUNICIPIO DE DUITAMA BOYACÁ		
CONVERSIONES		
CONTIENE:		
PLANTA ARQUITECTONICA VIVIENDA MODULAR		
LOCALIZACIÓN:		
ESCALA	FECHA	
	02/12/2022	
NOTA	FIRMA TUTOR	
PLANCHA N°	PLANCHA N°	
5		
REVISION	PLANO N°	PLANCHA N°
	A - 001	5
		DE:
		14

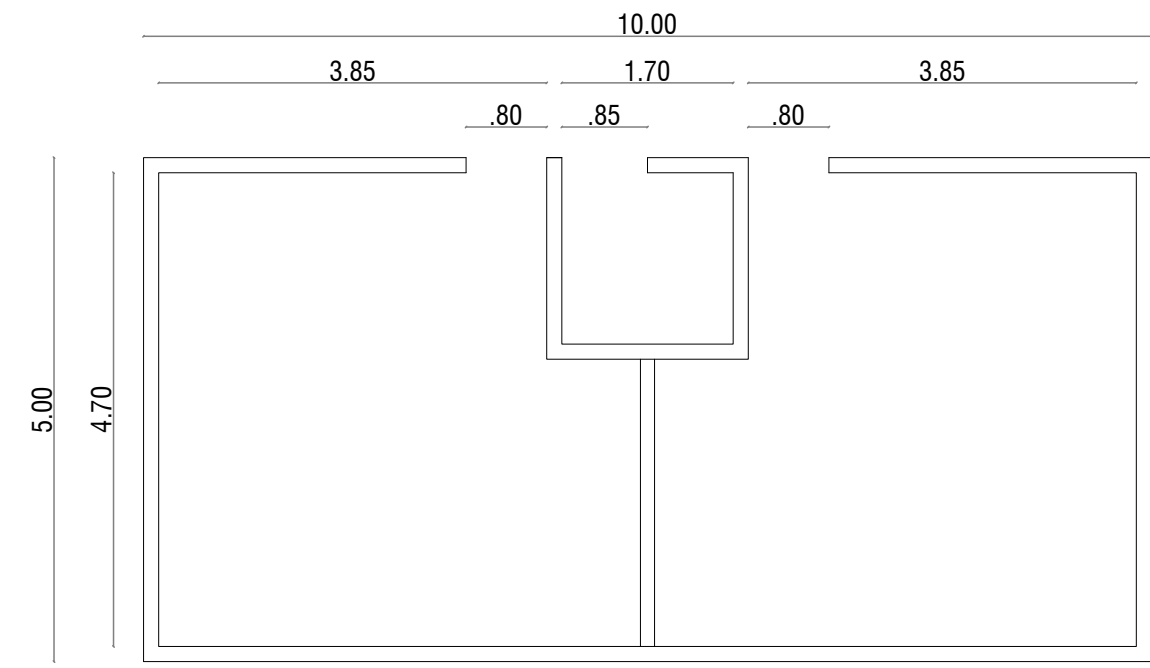

A PLANO CORRAL POLLOS
ESC:1:75

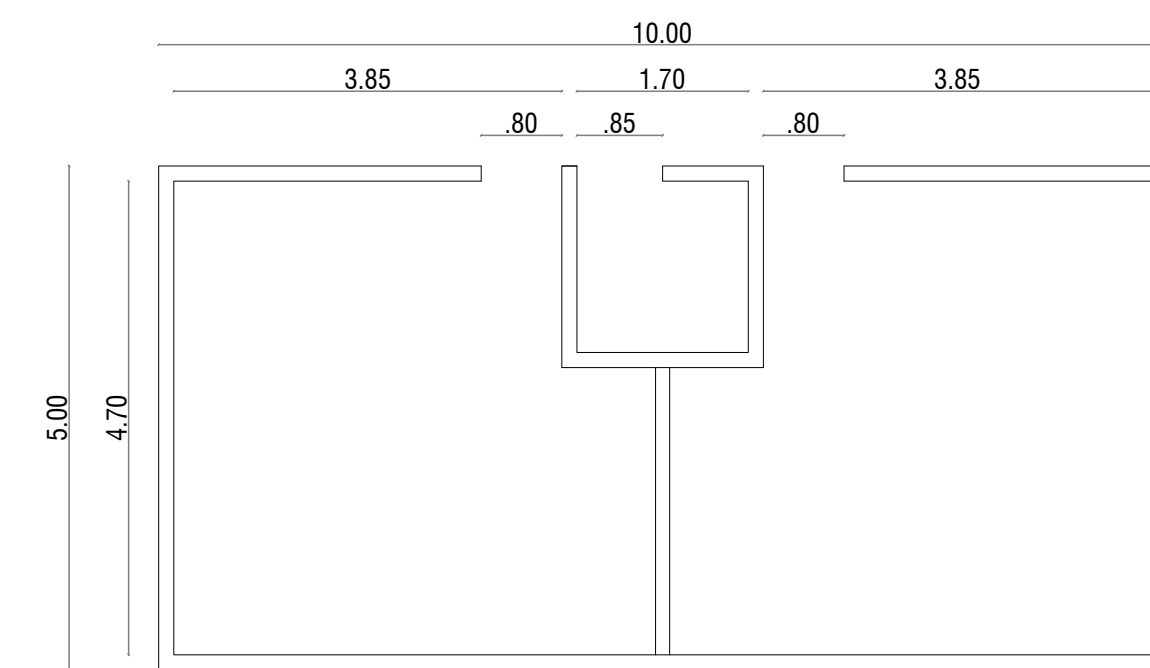

A PLANO CORRAL GALLINAS
ESC:1:75

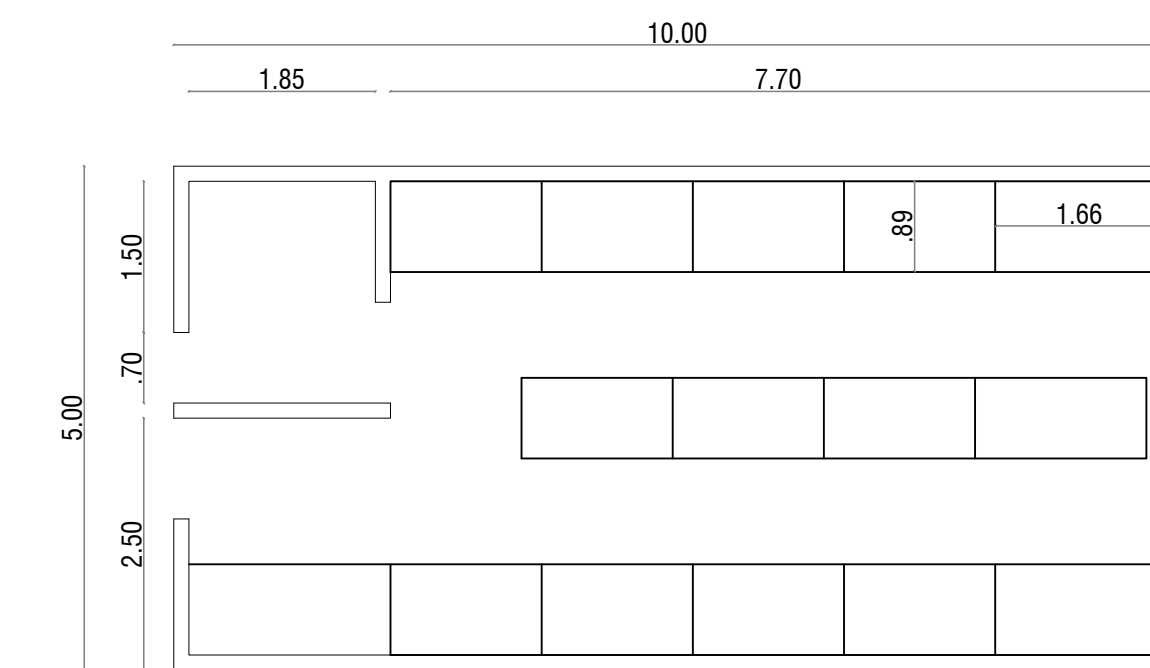

A PLANO CORRAL CONEJOS
ESC:1:75

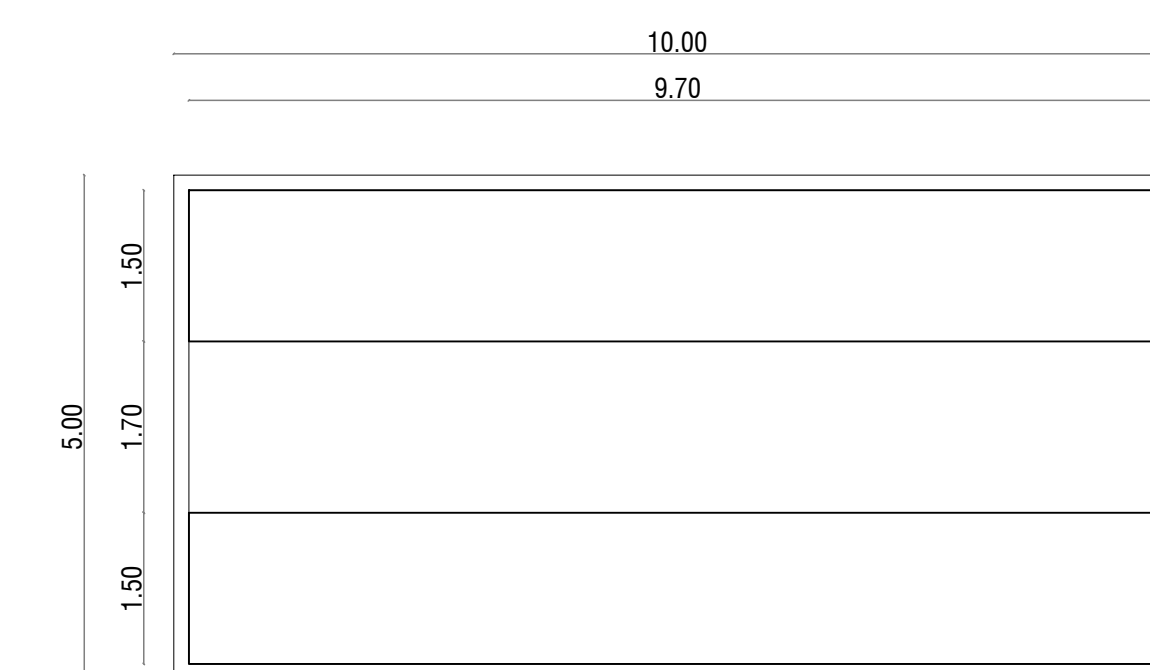

A PLANO LOMBRICULTIVO
ESC:1:75

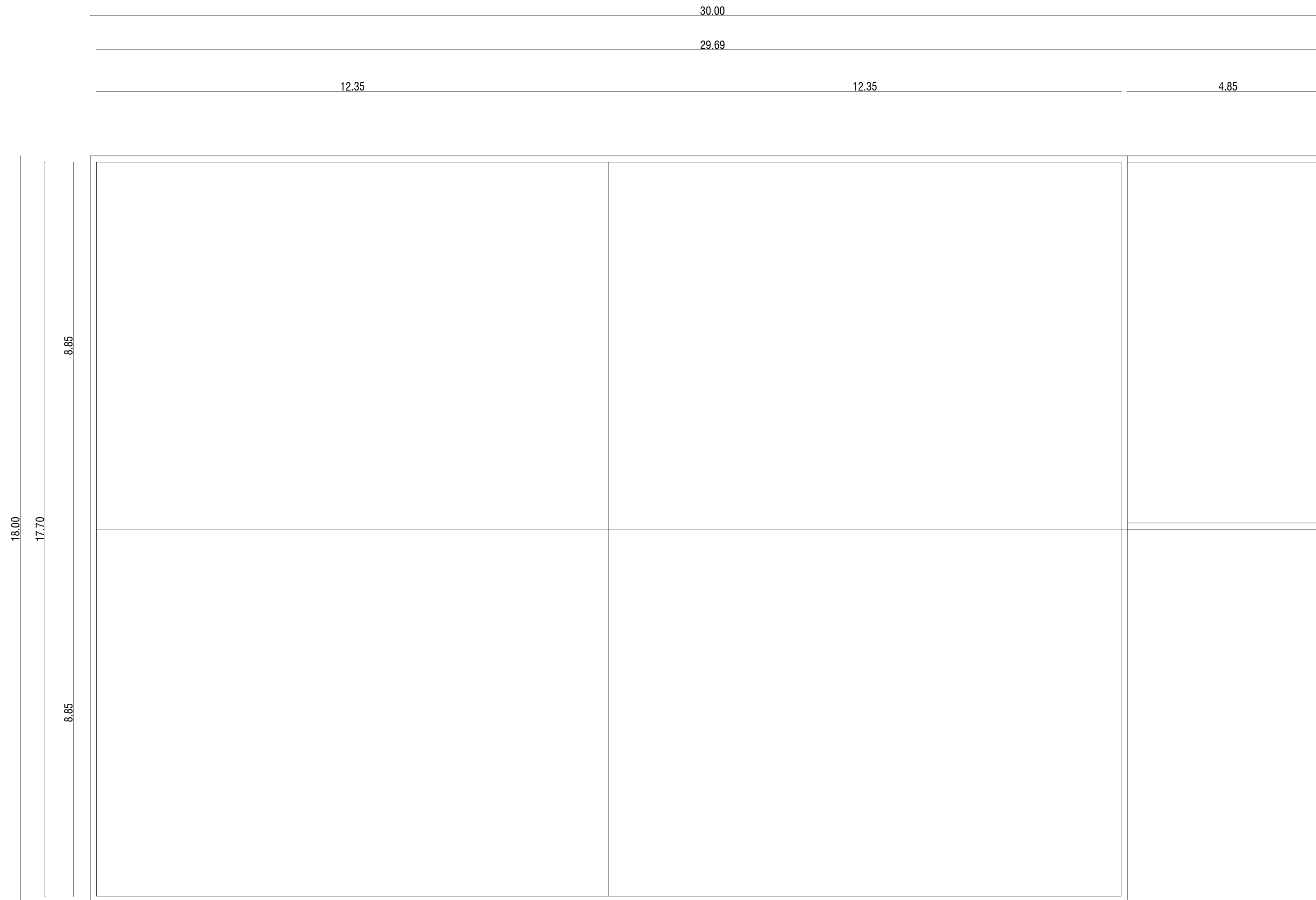

A PLANO CORRAL CERDOS
ESC:1:75

DE:	PLANO N°	REVISION
PLANCHA N°	PLANO N°	REVISION
FACULTAD DE ARQUITECTURA		
PROYECTO:		
MODELO AGROECOLÓGICO A PARTIR DE PROTOTIPOS SUSTENTABLES DE VIVIENDA RURAL PRODUCTIVA EN EL MUNICIPIO DE DUITAMA BOYACÁ		
CONVERSIONES		
CONTIENE:		
PLANTA ARQUITECTONICA CORRALES		
LOCALIZACIÓN:		
ESCALA	FECHA	
	02/12/2022	
NOTA	FIRMA TUTOR	
PLANCHA N°	PLANCHA N°	
6		
REVISION	PLANO N°	PLANCHA N°
	A - 002	6
		DE:
		14

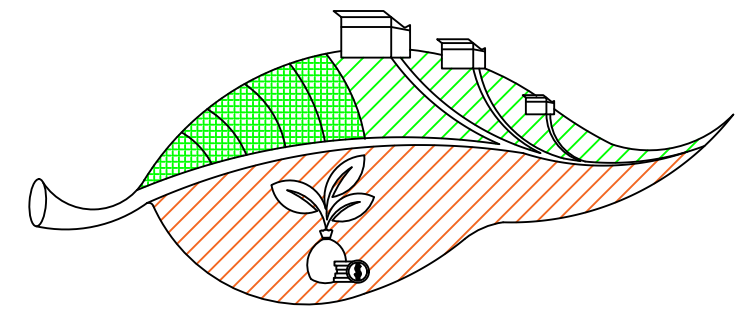
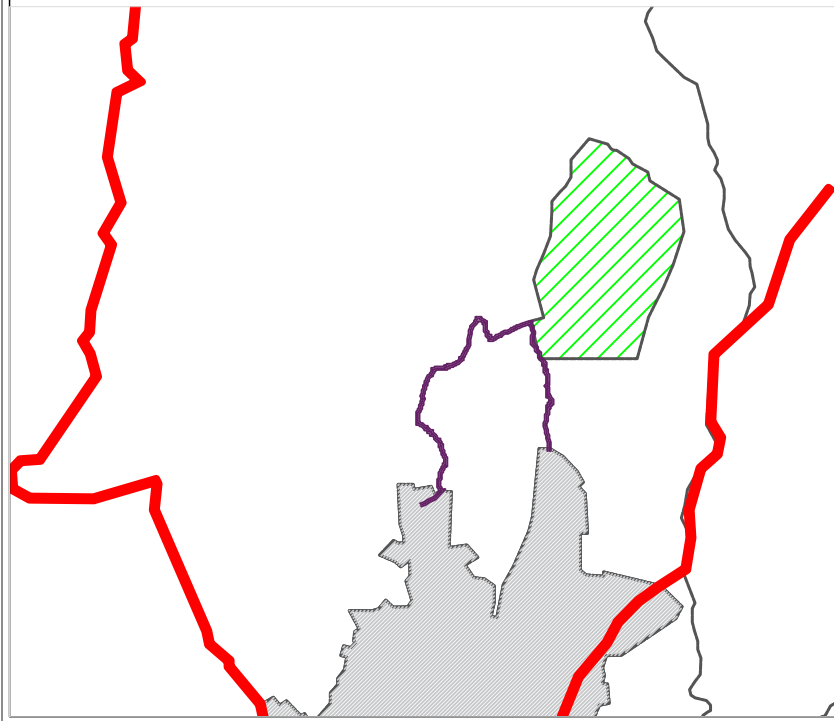
DE:	PLANO N°	REVISION
PLANCHA N°		
FACULTAD DE ARQUITECTURA		
		
PROYECTO:		
MODELO AGROECOLÓGICO A PARTIR DE PROTOTIPOS SUSTENTABLES DE VIVIENDA RURAL PRODUCTIVA EN EL MUNICIPIO DE DUITAMA BOYACÁ		
CONVERSIONES		
CONTIENE:		
PLANTA ARQUITECTONICA CUBIERTAS		
LOCALIZACIÓN:		
		
ESCALA	FECHA	
	02/12/2022	
NOTA	FIRMA TUTOR	
PLANCHA N°	PLANCHA N°	
7		
REVISION	PLANO N°	PLANCHA N°
	A - 003	7
		DE:
		14

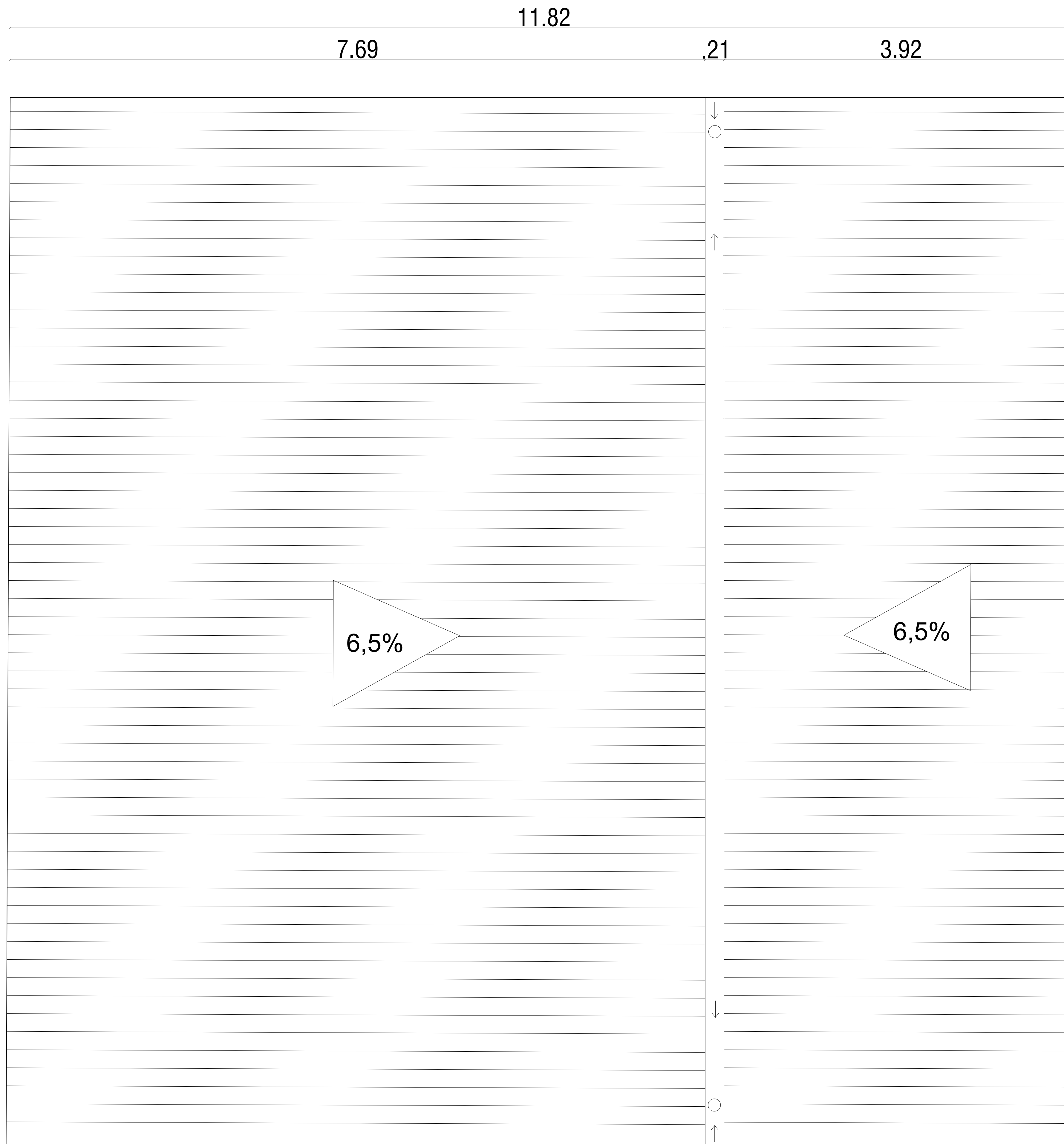

A PLANO ARQUITECTONICO CUBIERTA
ESC:1:25

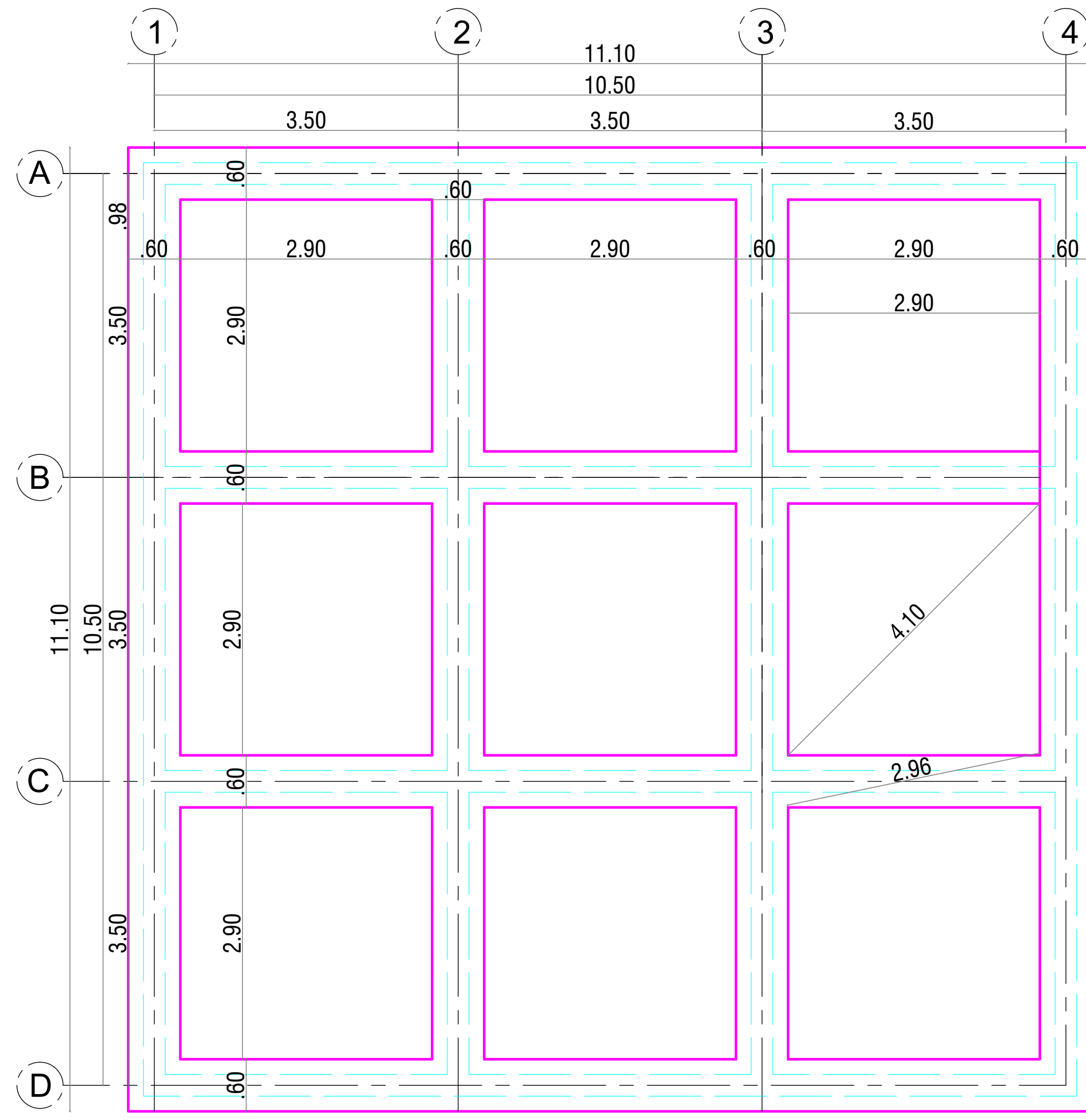

E PLANTA CIMENTACION CICLOPEA
ESC: 1:50

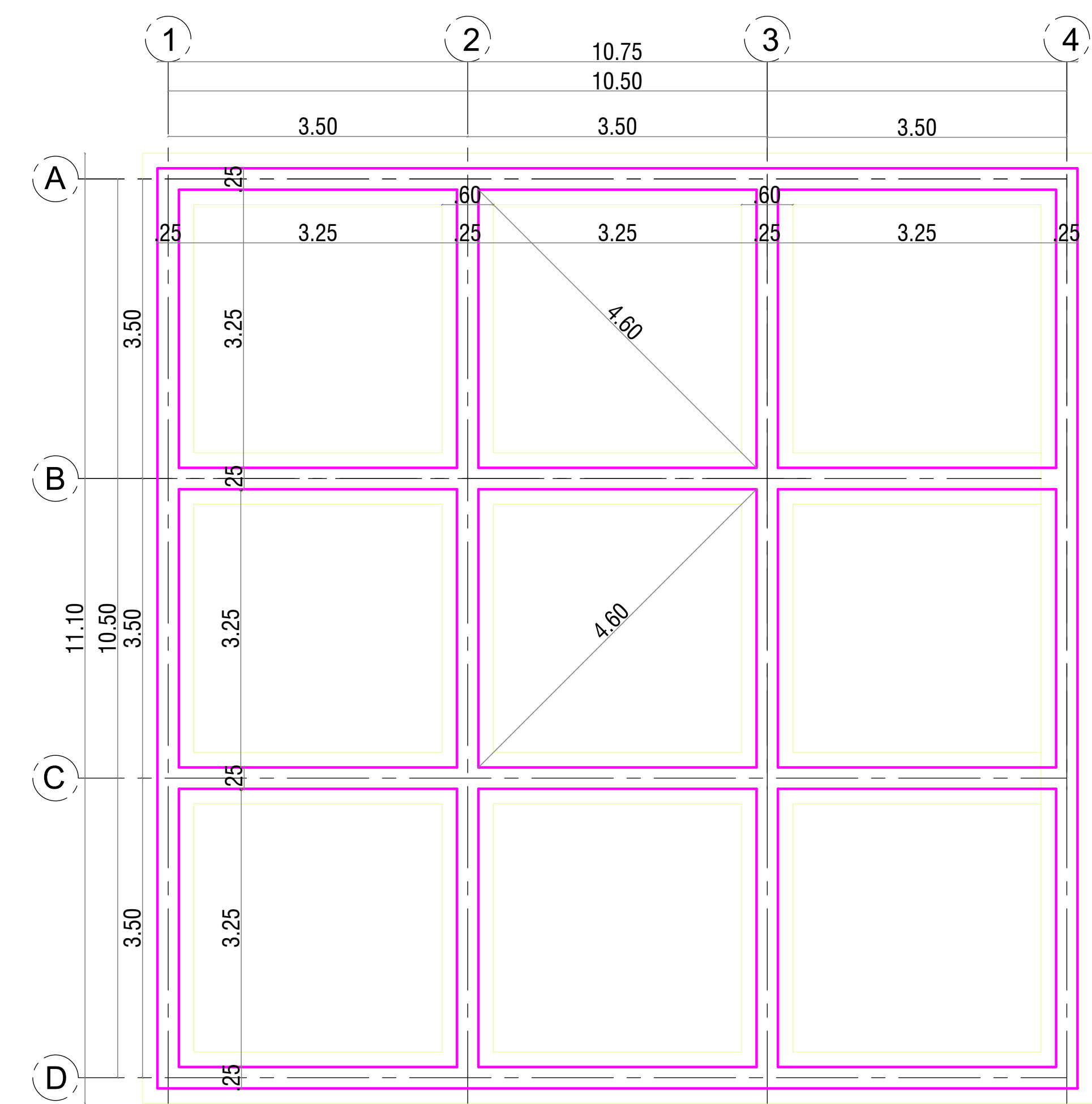

E PLANTA VIGA DE AMARRE
ESC: 1:50

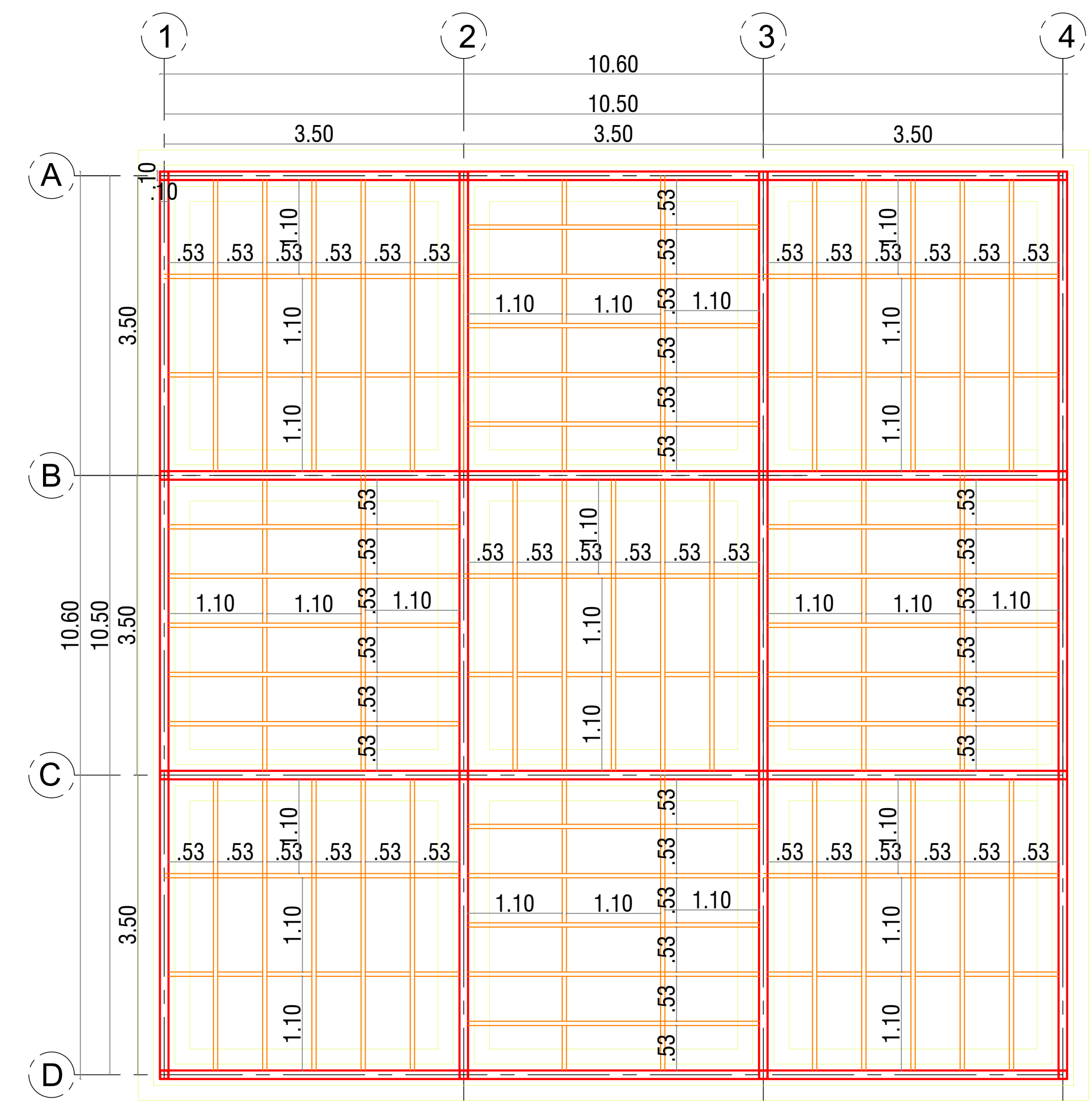

E PLANTA ESTRUCTURAL SOBRE PISO
ESC: 1:50

DE:	PLANO N°	REVISION
PLANCHAS N°	8	
FACULTAD DE ARQUITECTURA		
PROYECTO:		
MODELO AGROECOLÓGICO A PARTIR DE PROTOTIPOS SUSTENTABLES DE VIVIENDA RURAL PRODUCTIVA EN EL MUNICIPIO DE DUITAMA BOYACÁ		
CONVERSIONES		
	CIMENTACIÓN CICLOPEA	
	VIGA DE AMARRE	
	SOBRE PISO	
CONTIENE:		
PLANTA ESTRUCTURAL EJES Y CIMIENTOS		
LOCALIZACIÓN:		
ESCALA	FECHA	
	02/12/2022	
NOTA	FIRMA TUTOR	
PLANCHAS N°	PLANCHAS N°	
8		
REVISION	PLANO N°	PLANCHAS N°
	E - 001	8
		DE:
		14

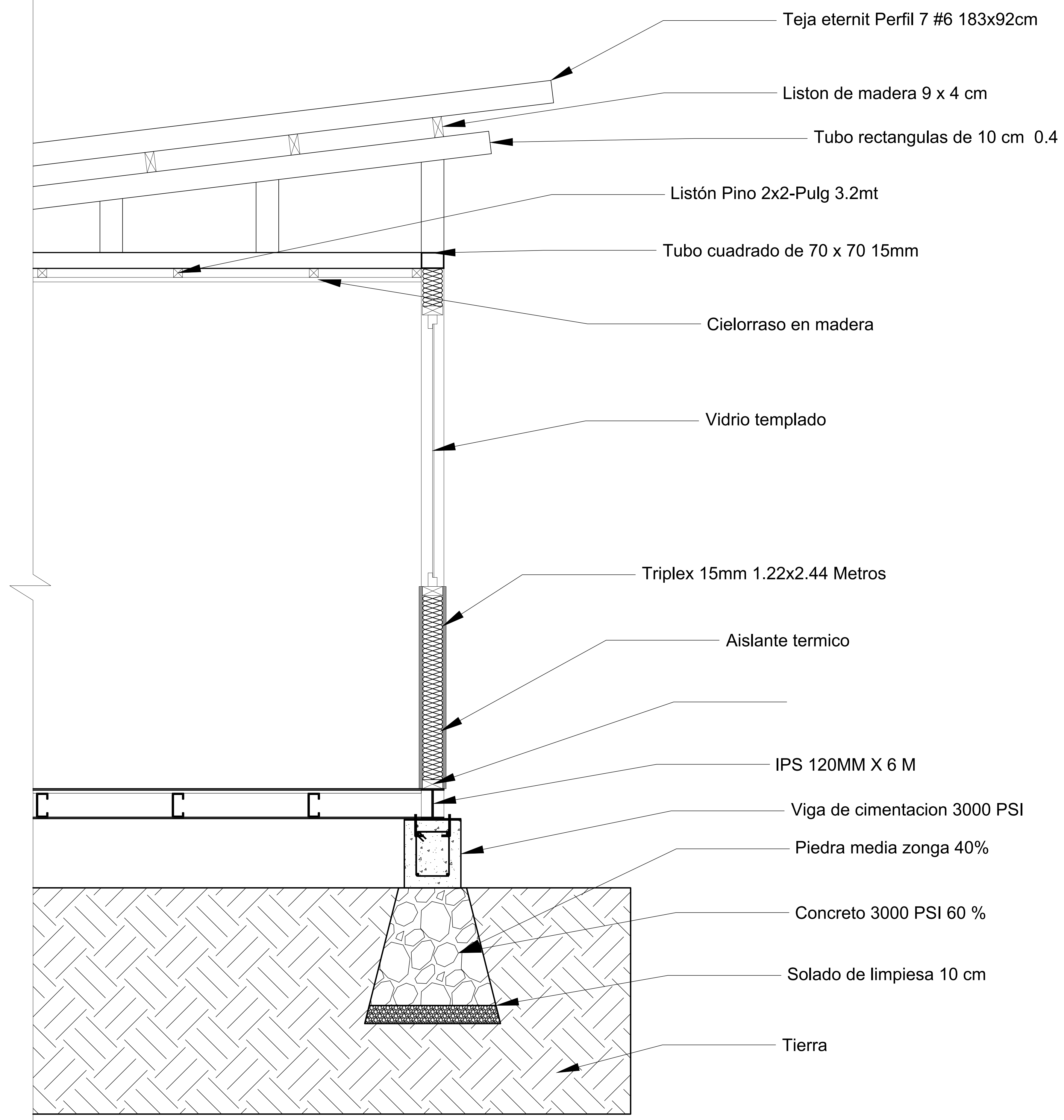

E

PLACA ESTRUCTURA CUBIERTA

ESC: 1:10

DE:	PLANO N°	REVISION
PLANCHA N°	PLANO N°	PLANCHA N°
FACULTAD DE ARQUITECTURA		
PROYECTO:		
MODELO AGROECOLÓGICO A PARTIR DE PROTOTIPOS SUSTENTABLES DE VIVIENDA RURAL PRODUCTIVA EN EL MUNICIPIO DE DUITAMA BOYACÁ		
CONVERSIONES		
CONTIENE:		
PLACA ESTRUCTURA CUBIERTA		
LOCALIZACIÓN:		
ESCALA	FECHA	
	02/12/2022	
NOTA	FIRMA TUTOR	
PLANCHA N°	PLANCHA N°	
9		
REVISION	PLANO N°	PLANCHA N°
	E - 002	9
		DE:
		14

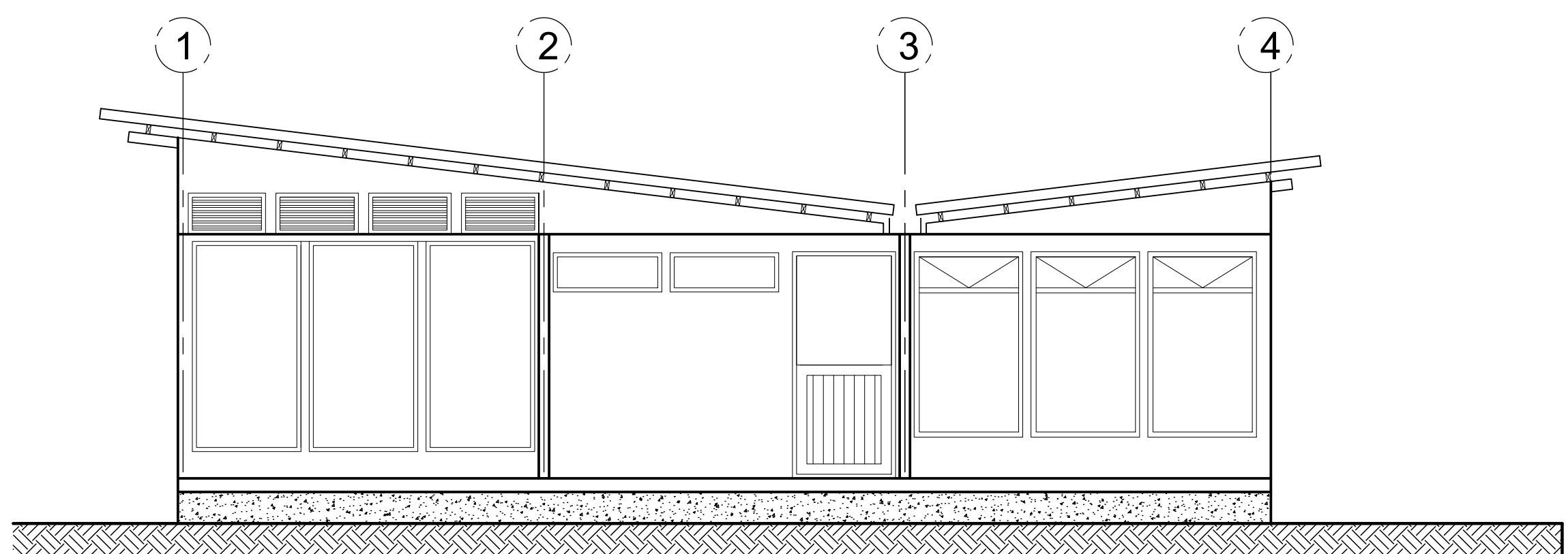

F FACHADA FRONTAL
ESC: 1:50

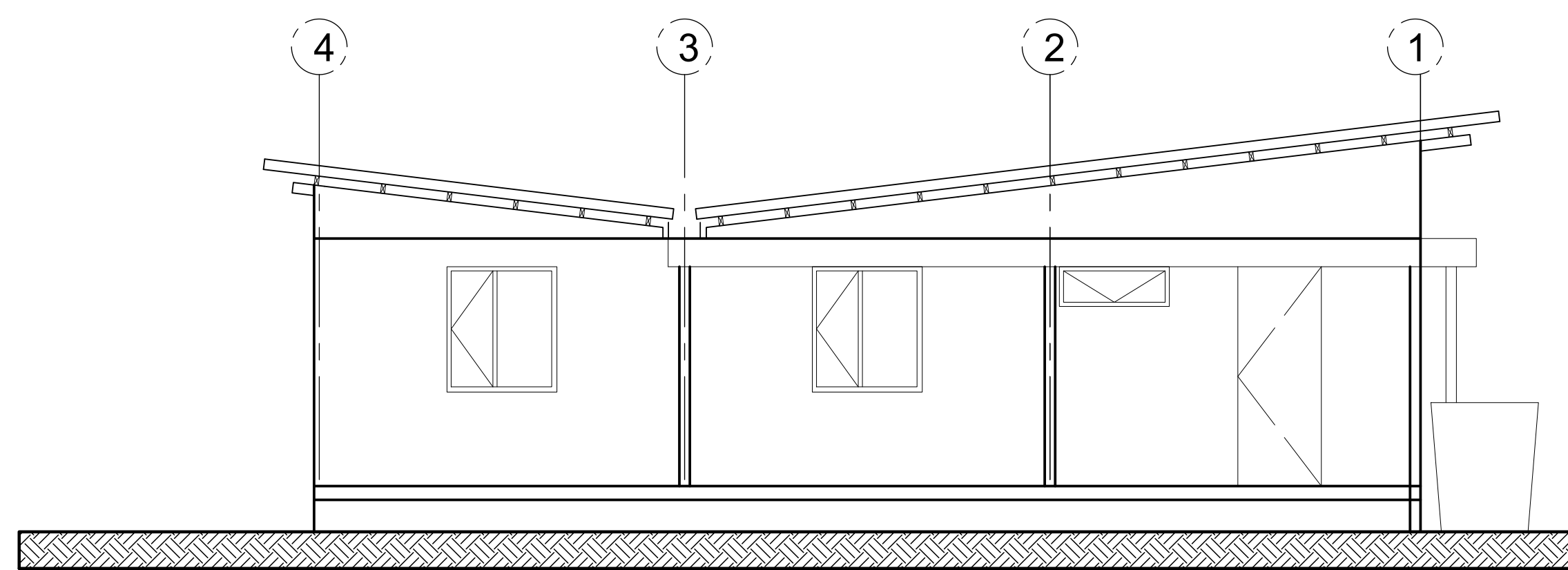

F FACHADA POSTERIOR
ESC: 1:50

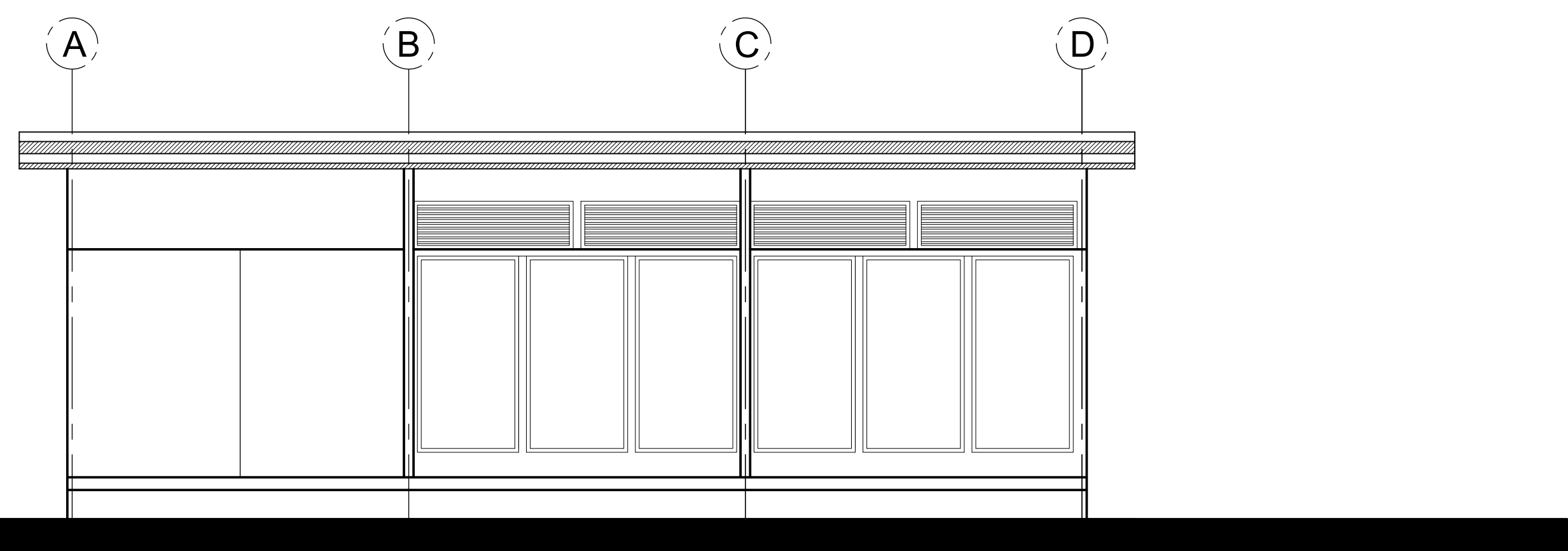

F FACHADA LATERAL IZQUIERDA
ESC: 1:50

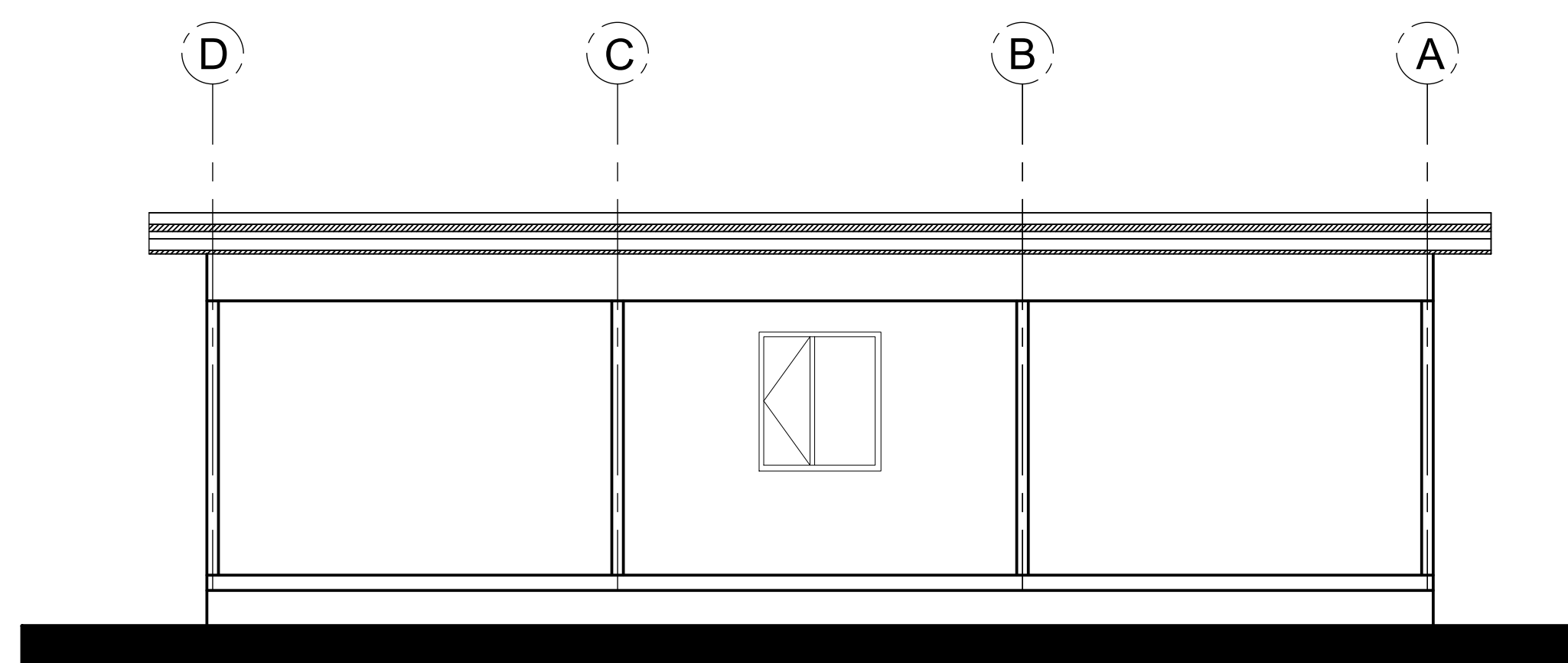

F FACHADA LATERAL DERECHA
ESC: 1:50



F FACHADA FRONTAL
ESC: 1:100

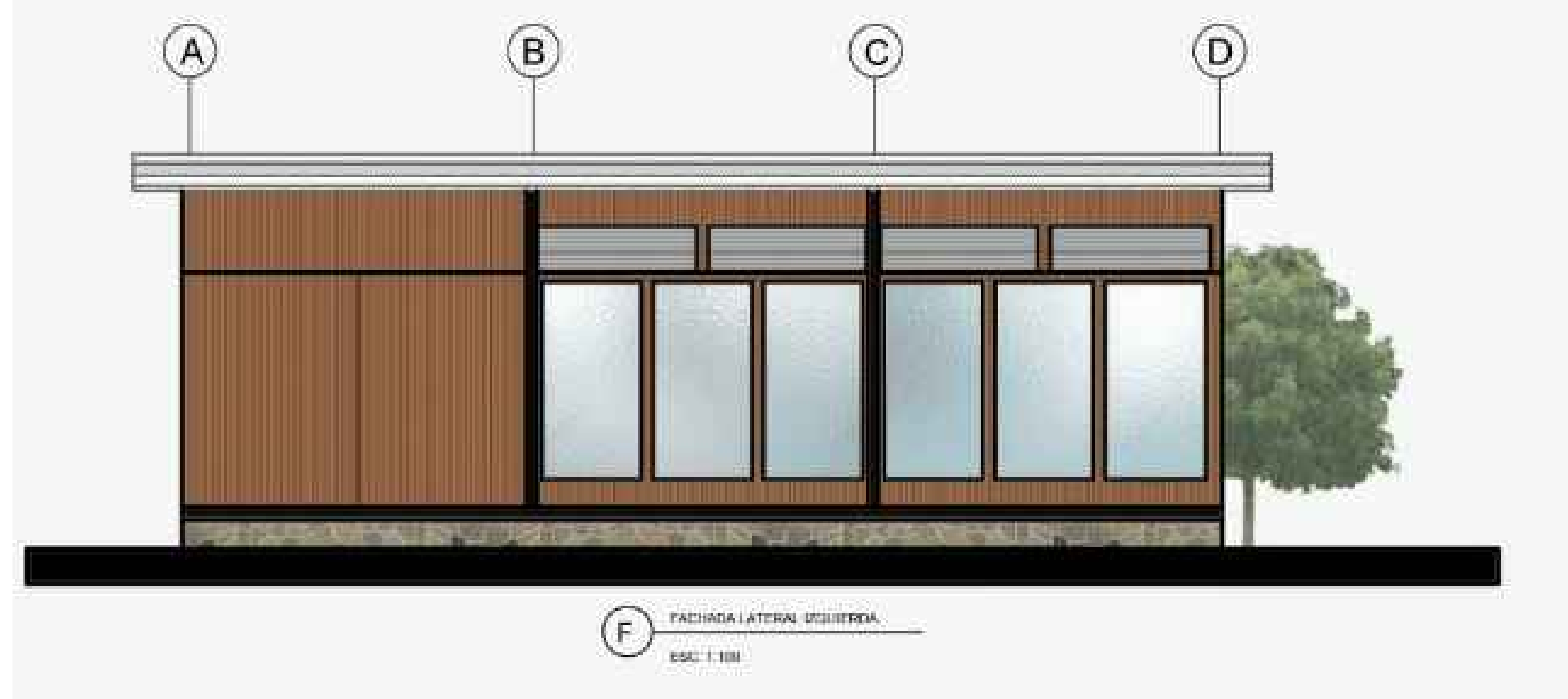

F FACHADA LATERAL IZQUIERDA
ESC: 1:100



F FACHADA POSTERIOR
ESC: 1:100



F FACHADA LATERAL DERECHA
ESC: 1:100

DE:	PLANO N°	REVISION
PLANCHA N°	PLANO N°	REVISION
FACULTAD DE ARQUITECTURA		
PROYECTO:		
MODELO AGROECOLÓGICO A PARTIR DE PROTOTIPOS SUSTENTABLES DE VIVIENDA RURAL PRODUCTIVA EN EL MUNICIPIO DE DUITAMA BOYACÁ		
CONVERSIONES		
CONTIENE:		
FACHADAS		
LOCALIZACIÓN:		
ESCALA	FECHA	
	02/12/2022	
NOTA	FIRMA TUTOR	
PLANCHA N°	PLANCHA N°	
10		
REVISION	PLANO N°	PLANCHA N°
	F - 001	10
		DE:
		14

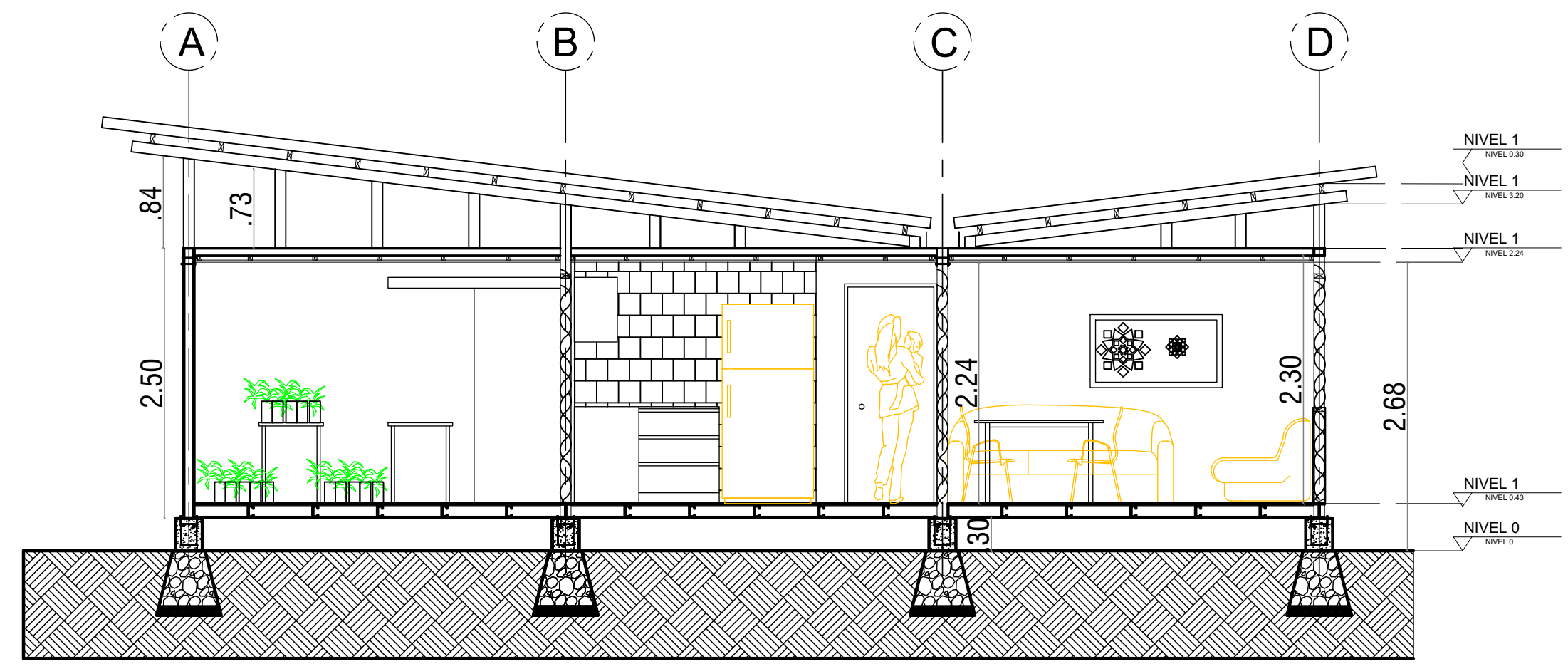

B CORTE LONGITUDINAL
ESC: 1:50

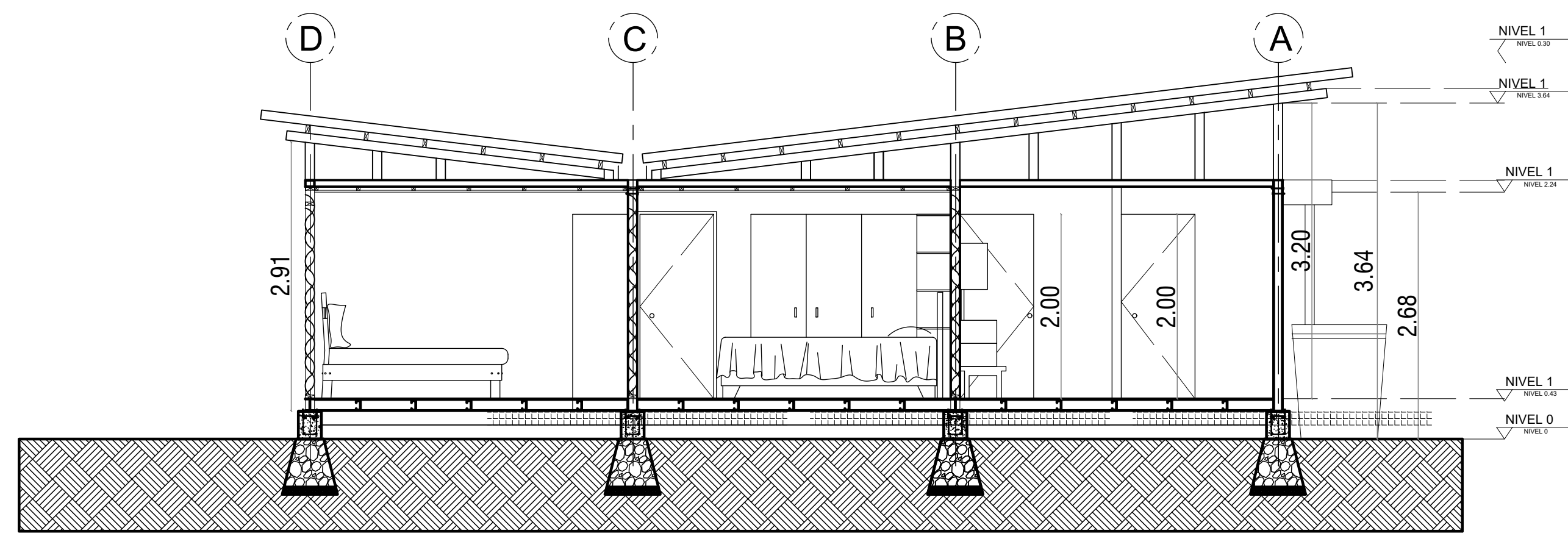

B CORTE LONGITUDINAL
ESC: 1:50

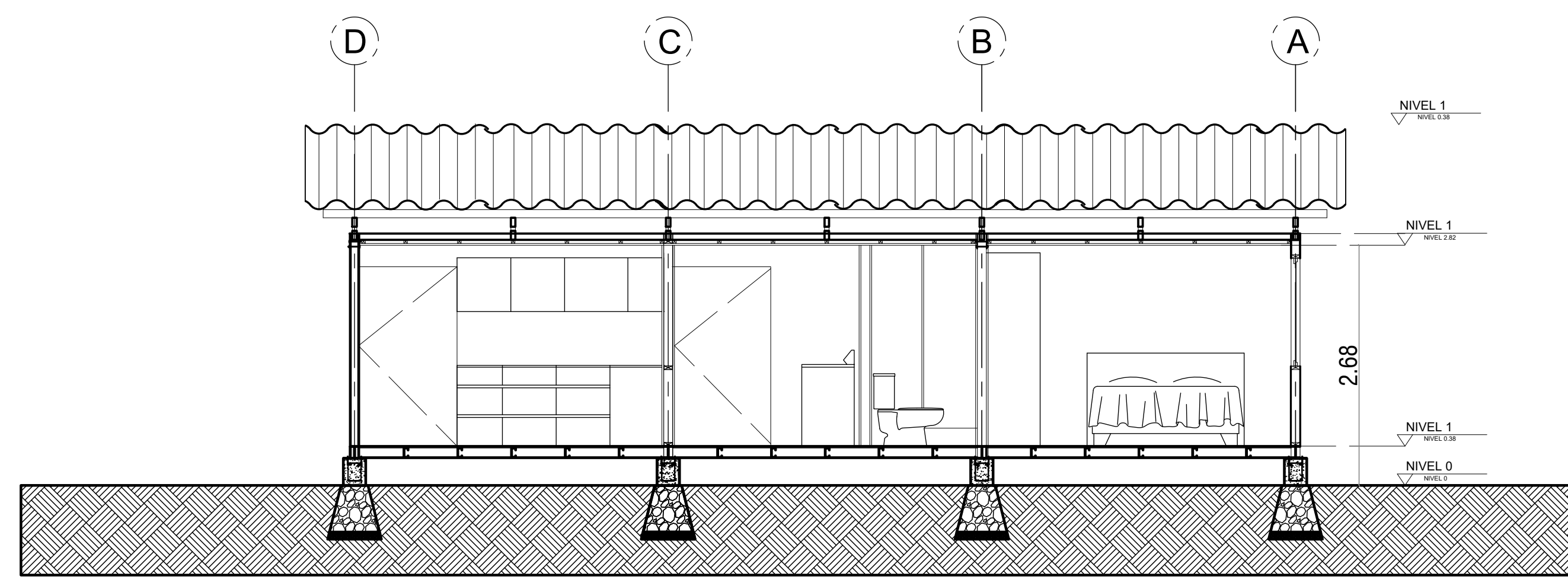

B CORTE TRANSVERSAL
ESC: 1:50

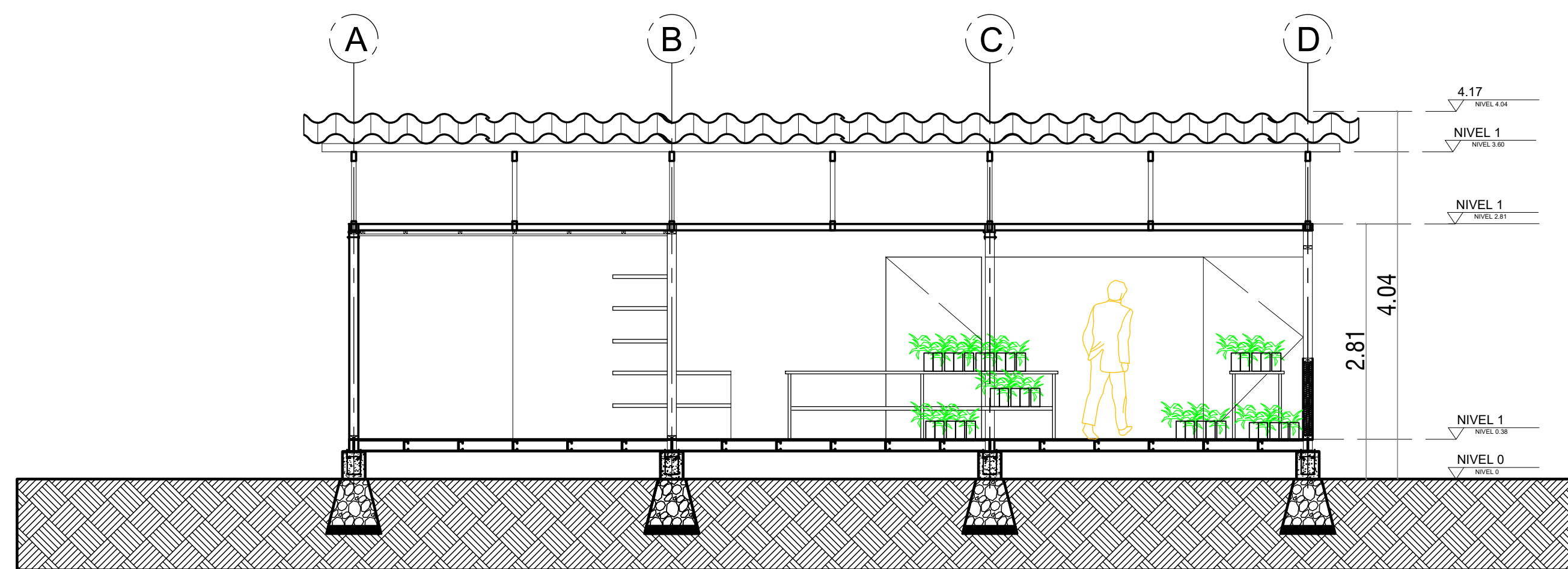

B CORTE TRANSVERSAL
ESC: 1:50

DE:	PLANO N°	REVISION
PLANCHA N°	PLANO N°	REVISION
FACULTAD DE ARQUITECTURA		
PROYECTO: MODELO AGROECOLÓGICO A PARTIR DE PROTOTIPOS SUSTENTABLES DE VIVIENDA RURAL PRODUCTIVA EN EL MUNICIPIO DE DUITAMA BOYACÁ		
CONVERSIONES		
CONTIENE: CORTES - LONGITUDINALES Y TRANSVERSALES VIVIENDA PROGRESIVA		
LOCALIZACIÓN:		
ESCALA	FECHA	
	02/12/2022	
NOTA	FIRMA TUTOR	
PLANCHA N°	PLANCHA N°	
11		
REVISION	PLANO N°	PLANCHA N°
	B - 001	11
		DE:
		14

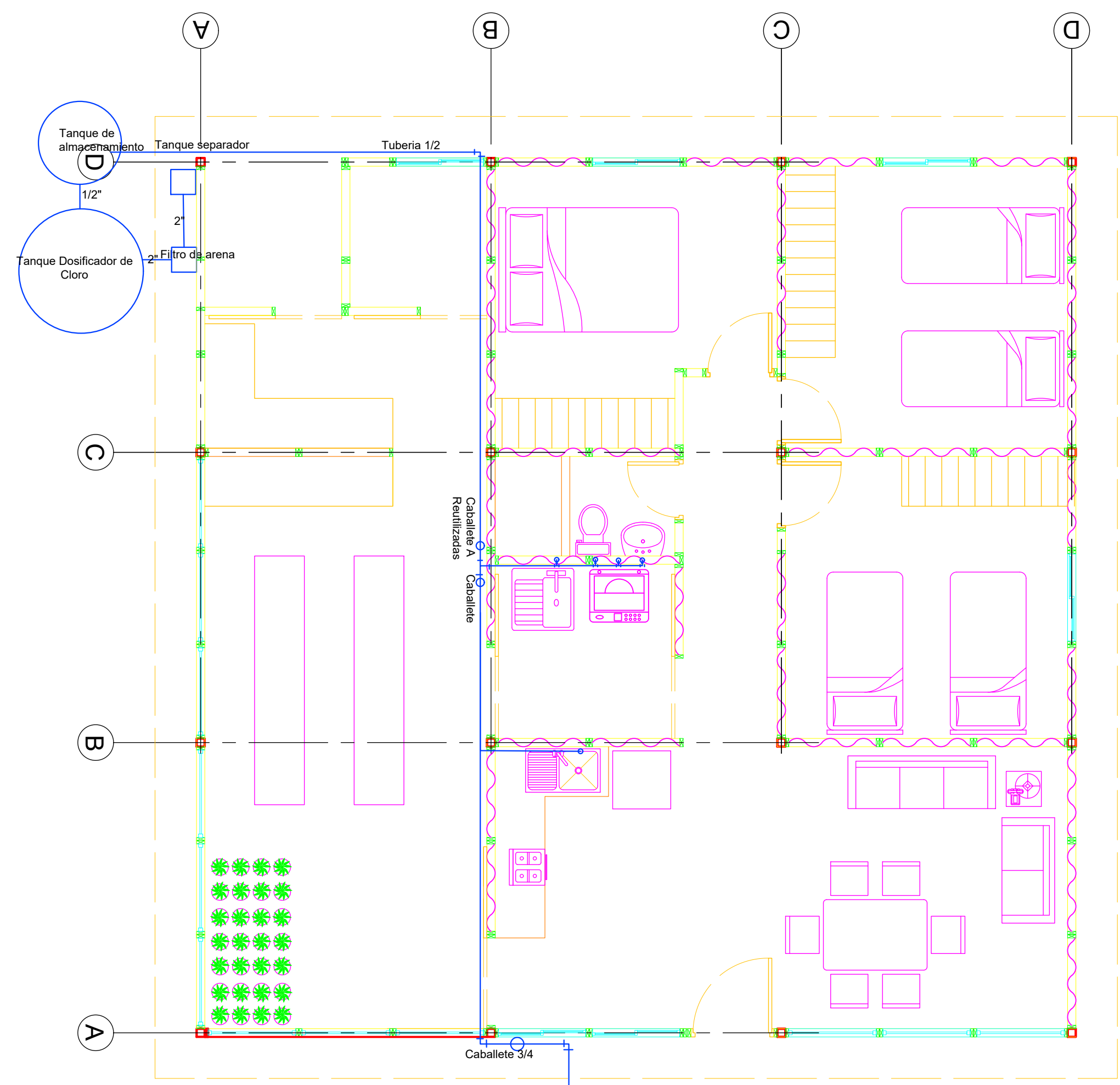

P PLANO INSTALACIONES AGUA POTABLE
ESC: 1:50

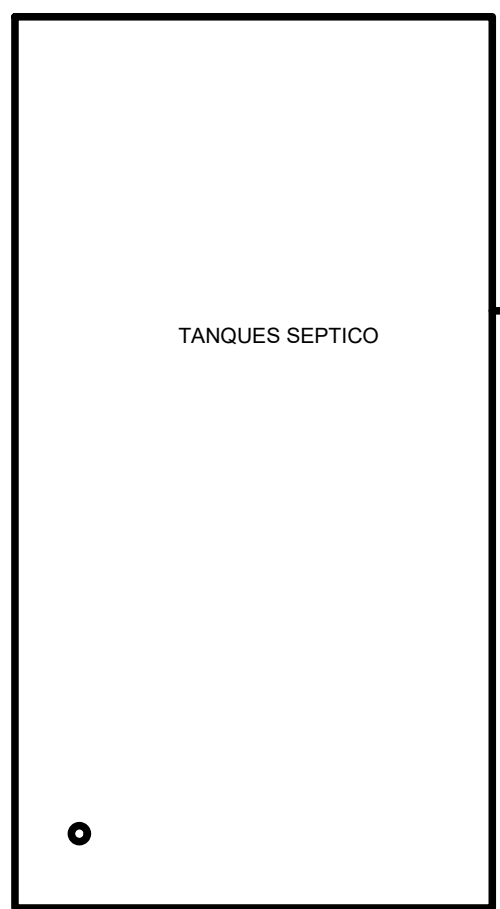

P PLANOS DESAGUES
ESC: 1:50

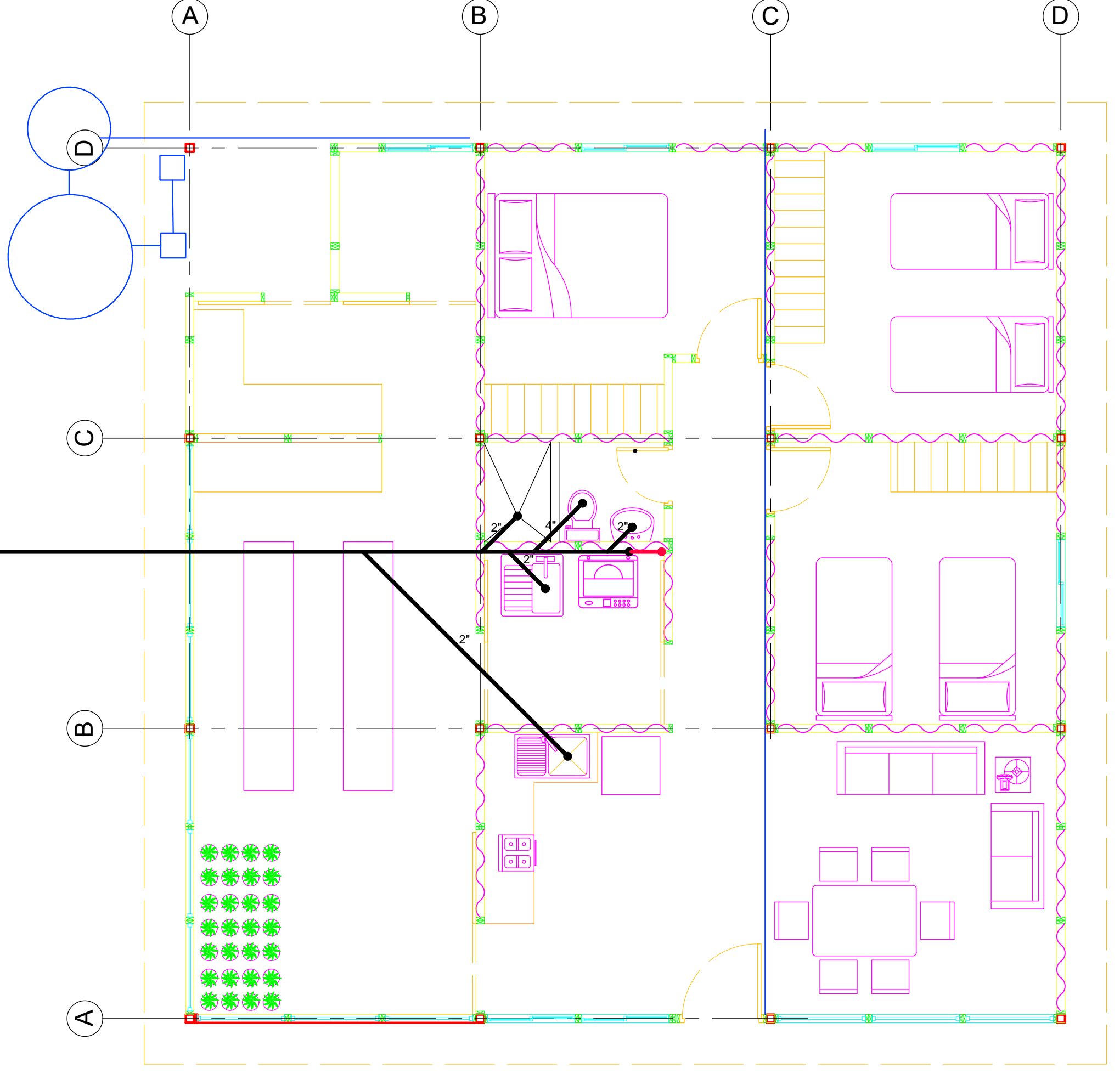

- Tubería de Agua
- Yee de 45°
- Codo 90°
- Codo 45°
- Tee
- Yee
- Flujo de dirección

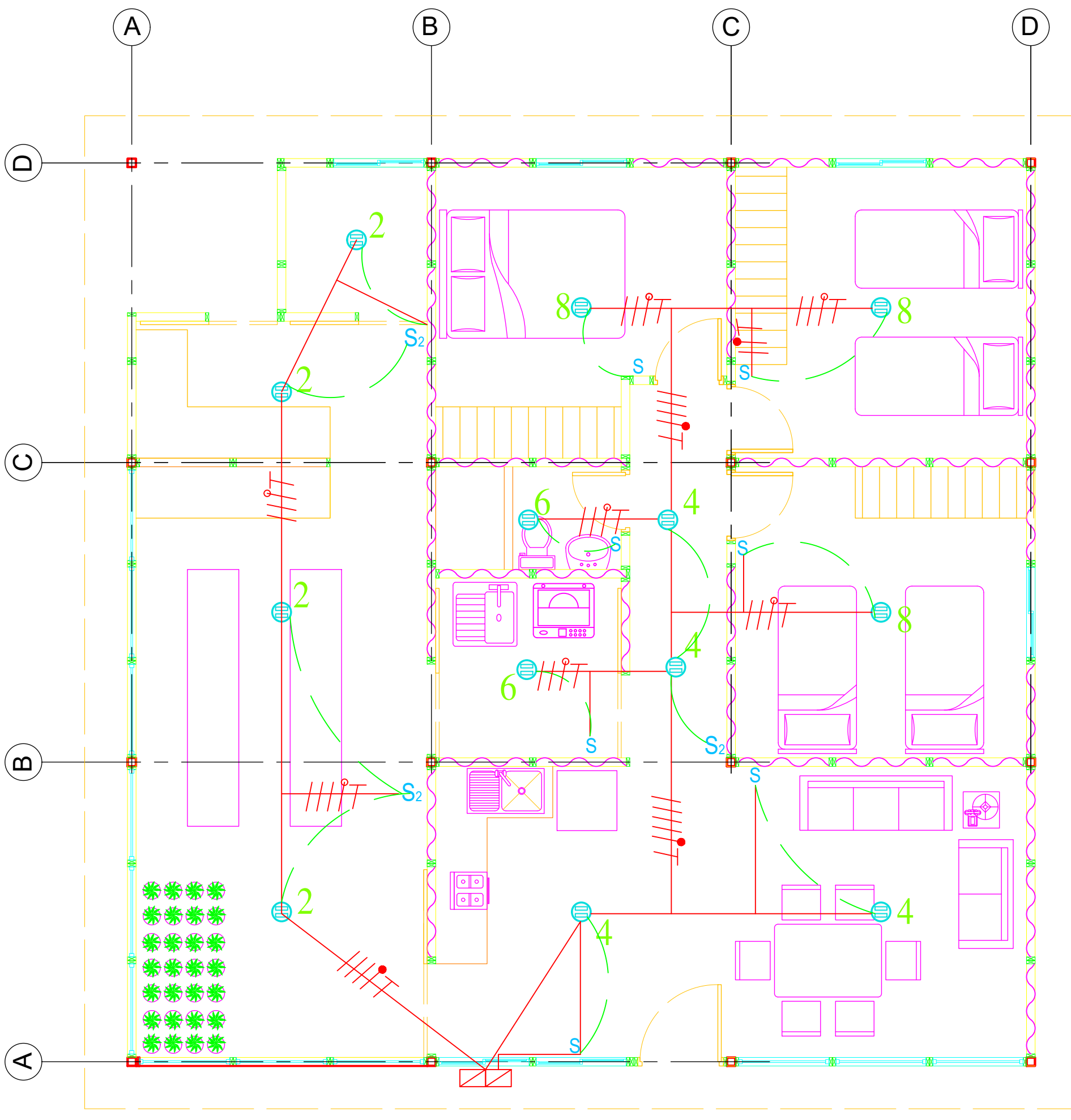

P PLANO INSTALACIONES ELECTRICAS
ESC: 1:50

REVISION	PLANO N°	PLANCHA N°																																																																																																						
12	P - 001	12																																																																																																						
DE:		14																																																																																																						
FACULTAD DE ARQUITECTURA																																																																																																								
PROYECTO:																																																																																																								
MODELO AGROECOLÓGICO A PARTIR DE PROTOTIPOS SUSTENTABLES DE VIVIENDA RURAL PRODUCTIVA EN EL MUNICIPIO DE DUITAMA BOYACÁ																																																																																																								
CONVERSIONES																																																																																																								
<table border="1" style="width: 100%; border-collapse: collapse;"> <thead> <tr> <th>CONVERSIONES</th> <th>ILUMINACION</th> </tr> </thead> <tbody> <tr> <td>1. [Symbol] [Text]</td> <td>1. [Symbol] [Text]</td> </tr> <tr> <td>2. [Symbol] [Text]</td> <td>2. [Symbol] [Text]</td> </tr> <tr> <td>3. [Symbol] [Text]</td> <td>3. [Symbol] [Text]</td> </tr> <tr> <td>4. [Symbol] [Text]</td> <td>4. [Symbol] [Text]</td> </tr> <tr> <td>5. [Symbol] [Text]</td> <td>5. [Symbol] [Text]</td> </tr> <tr> <td>6. [Symbol] [Text]</td> <td>6. [Symbol] [Text]</td> </tr> <tr> <td>7. [Symbol] [Text]</td> <td>7. [Symbol] [Text]</td> </tr> <tr> <td>8. [Symbol] [Text]</td> <td>8. [Symbol] [Text]</td> </tr> <tr> <td>9. [Symbol] [Text]</td> <td>9. [Symbol] [Text]</td> </tr> <tr> <td>10. [Symbol] [Text]</td> <td>10. [Symbol] [Text]</td> </tr> <tr> <td>11. [Symbol] [Text]</td> <td>11. [Symbol] [Text]</td> </tr> <tr> <td>12. [Symbol] [Text]</td> <td>12. [Symbol] [Text]</td> </tr> <tr> <td>13. [Symbol] [Text]</td> <td>13. [Symbol] [Text]</td> </tr> <tr> <td>14. [Symbol] [Text]</td> <td>14. [Symbol] [Text]</td> </tr> <tr> <td>15. [Symbol] [Text]</td> <td>15. [Symbol] [Text]</td> </tr> <tr> <td>16. [Symbol] [Text]</td> <td>16. [Symbol] [Text]</td> </tr> <tr> <td>17. [Symbol] [Text]</td> <td>17. [Symbol] [Text]</td> </tr> <tr> <td>18. [Symbol] [Text]</td> <td>18. [Symbol] [Text]</td> </tr> <tr> <td>19. [Symbol] [Text]</td> <td>19. [Symbol] [Text]</td> </tr> <tr> <td>20. [Symbol] [Text]</td> <td>20. [Symbol] [Text]</td> </tr> <tr> <td>21. [Symbol] [Text]</td> <td>21. [Symbol] [Text]</td> </tr> <tr> <td>22. [Symbol] [Text]</td> <td>22. [Symbol] [Text]</td> </tr> <tr> <td>23. [Symbol] [Text]</td> <td>23. [Symbol] [Text]</td> </tr> <tr> <td>24. [Symbol] [Text]</td> <td>24. [Symbol] [Text]</td> </tr> <tr> <td>25. [Symbol] [Text]</td> <td>25. [Symbol] [Text]</td> </tr> <tr> <td>26. [Symbol] [Text]</td> <td>26. [Symbol] [Text]</td> </tr> <tr> <td>27. [Symbol] [Text]</td> <td>27. [Symbol] [Text]</td> </tr> <tr> <td>28. [Symbol] [Text]</td> <td>28. [Symbol] [Text]</td> </tr> <tr> <td>29. [Symbol] [Text]</td> <td>29. [Symbol] [Text]</td> </tr> <tr> <td>30. [Symbol] [Text]</td> <td>30. [Symbol] [Text]</td> </tr> <tr> <td>31. [Symbol] [Text]</td> <td>31. [Symbol] [Text]</td> </tr> <tr> <td>32. [Symbol] [Text]</td> <td>32. [Symbol] [Text]</td> </tr> <tr> <td>33. [Symbol] [Text]</td> <td>33. [Symbol] [Text]</td> </tr> <tr> <td>34. [Symbol] [Text]</td> <td>34. [Symbol] [Text]</td> </tr> <tr> <td>35. [Symbol] [Text]</td> <td>35. [Symbol] [Text]</td> </tr> <tr> <td>36. [Symbol] [Text]</td> <td>36. [Symbol] [Text]</td> </tr> <tr> <td>37. [Symbol] [Text]</td> <td>37. [Symbol] [Text]</td> </tr> <tr> <td>38. [Symbol] [Text]</td> <td>38. [Symbol] [Text]</td> </tr> <tr> <td>39. [Symbol] [Text]</td> <td>39. [Symbol] [Text]</td> </tr> <tr> <td>40. [Symbol] [Text]</td> <td>40. [Symbol] [Text]</td> </tr> <tr> <td>41. [Symbol] [Text]</td> <td>41. [Symbol] [Text]</td> </tr> <tr> <td>42. [Symbol] [Text]</td> <td>42. [Symbol] [Text]</td> </tr> <tr> <td>43. [Symbol] [Text]</td> <td>43. [Symbol] [Text]</td> </tr> <tr> <td>44. [Symbol] [Text]</td> <td>44. [Symbol] [Text]</td> </tr> <tr> <td>45. [Symbol] [Text]</td> <td>45. [Symbol] [Text]</td> </tr> <tr> <td>46. [Symbol] [Text]</td> <td>46. [Symbol] [Text]</td> </tr> <tr> <td>47. [Symbol] [Text]</td> <td>47. [Symbol] [Text]</td> </tr> <tr> <td>48. [Symbol] [Text]</td> <td>48. [Symbol] [Text]</td> </tr> <tr> <td>49. [Symbol] [Text]</td> <td>49. [Symbol] [Text]</td> </tr> <tr> <td>50. [Symbol] [Text]</td> <td>50. [Symbol] [Text]</td> </tr> </tbody> </table>			CONVERSIONES	ILUMINACION	1. [Symbol] [Text]	1. [Symbol] [Text]	2. [Symbol] [Text]	2. [Symbol] [Text]	3. [Symbol] [Text]	3. [Symbol] [Text]	4. [Symbol] [Text]	4. [Symbol] [Text]	5. [Symbol] [Text]	5. [Symbol] [Text]	6. [Symbol] [Text]	6. [Symbol] [Text]	7. [Symbol] [Text]	7. [Symbol] [Text]	8. [Symbol] [Text]	8. [Symbol] [Text]	9. [Symbol] [Text]	9. [Symbol] [Text]	10. [Symbol] [Text]	10. [Symbol] [Text]	11. [Symbol] [Text]	11. [Symbol] [Text]	12. [Symbol] [Text]	12. [Symbol] [Text]	13. [Symbol] [Text]	13. [Symbol] [Text]	14. [Symbol] [Text]	14. [Symbol] [Text]	15. [Symbol] [Text]	15. [Symbol] [Text]	16. [Symbol] [Text]	16. [Symbol] [Text]	17. [Symbol] [Text]	17. [Symbol] [Text]	18. [Symbol] [Text]	18. [Symbol] [Text]	19. [Symbol] [Text]	19. [Symbol] [Text]	20. [Symbol] [Text]	20. [Symbol] [Text]	21. [Symbol] [Text]	21. [Symbol] [Text]	22. [Symbol] [Text]	22. [Symbol] [Text]	23. [Symbol] [Text]	23. [Symbol] [Text]	24. [Symbol] [Text]	24. [Symbol] [Text]	25. [Symbol] [Text]	25. [Symbol] [Text]	26. [Symbol] [Text]	26. [Symbol] [Text]	27. [Symbol] [Text]	27. [Symbol] [Text]	28. [Symbol] [Text]	28. [Symbol] [Text]	29. [Symbol] [Text]	29. [Symbol] [Text]	30. [Symbol] [Text]	30. [Symbol] [Text]	31. [Symbol] [Text]	31. [Symbol] [Text]	32. [Symbol] [Text]	32. [Symbol] [Text]	33. [Symbol] [Text]	33. [Symbol] [Text]	34. [Symbol] [Text]	34. [Symbol] [Text]	35. [Symbol] [Text]	35. [Symbol] [Text]	36. [Symbol] [Text]	36. [Symbol] [Text]	37. [Symbol] [Text]	37. [Symbol] [Text]	38. [Symbol] [Text]	38. [Symbol] [Text]	39. [Symbol] [Text]	39. [Symbol] [Text]	40. [Symbol] [Text]	40. [Symbol] [Text]	41. [Symbol] [Text]	41. [Symbol] [Text]	42. [Symbol] [Text]	42. [Symbol] [Text]	43. [Symbol] [Text]	43. [Symbol] [Text]	44. [Symbol] [Text]	44. [Symbol] [Text]	45. [Symbol] [Text]	45. [Symbol] [Text]	46. [Symbol] [Text]	46. [Symbol] [Text]	47. [Symbol] [Text]	47. [Symbol] [Text]	48. [Symbol] [Text]	48. [Symbol] [Text]	49. [Symbol] [Text]	49. [Symbol] [Text]	50. [Symbol] [Text]	50. [Symbol] [Text]
CONVERSIONES	ILUMINACION																																																																																																							
1. [Symbol] [Text]	1. [Symbol] [Text]																																																																																																							
2. [Symbol] [Text]	2. [Symbol] [Text]																																																																																																							
3. [Symbol] [Text]	3. [Symbol] [Text]																																																																																																							
4. [Symbol] [Text]	4. [Symbol] [Text]																																																																																																							
5. [Symbol] [Text]	5. [Symbol] [Text]																																																																																																							
6. [Symbol] [Text]	6. [Symbol] [Text]																																																																																																							
7. [Symbol] [Text]	7. [Symbol] [Text]																																																																																																							
8. [Symbol] [Text]	8. [Symbol] [Text]																																																																																																							
9. [Symbol] [Text]	9. [Symbol] [Text]																																																																																																							
10. [Symbol] [Text]	10. [Symbol] [Text]																																																																																																							
11. [Symbol] [Text]	11. [Symbol] [Text]																																																																																																							
12. [Symbol] [Text]	12. [Symbol] [Text]																																																																																																							
13. [Symbol] [Text]	13. [Symbol] [Text]																																																																																																							
14. [Symbol] [Text]	14. [Symbol] [Text]																																																																																																							
15. [Symbol] [Text]	15. [Symbol] [Text]																																																																																																							
16. [Symbol] [Text]	16. [Symbol] [Text]																																																																																																							
17. [Symbol] [Text]	17. [Symbol] [Text]																																																																																																							
18. [Symbol] [Text]	18. [Symbol] [Text]																																																																																																							
19. [Symbol] [Text]	19. [Symbol] [Text]																																																																																																							
20. [Symbol] [Text]	20. [Symbol] [Text]																																																																																																							
21. [Symbol] [Text]	21. [Symbol] [Text]																																																																																																							
22. [Symbol] [Text]	22. [Symbol] [Text]																																																																																																							
23. [Symbol] [Text]	23. [Symbol] [Text]																																																																																																							
24. [Symbol] [Text]	24. [Symbol] [Text]																																																																																																							
25. [Symbol] [Text]	25. [Symbol] [Text]																																																																																																							
26. [Symbol] [Text]	26. [Symbol] [Text]																																																																																																							
27. [Symbol] [Text]	27. [Symbol] [Text]																																																																																																							
28. [Symbol] [Text]	28. [Symbol] [Text]																																																																																																							
29. [Symbol] [Text]	29. [Symbol] [Text]																																																																																																							
30. [Symbol] [Text]	30. [Symbol] [Text]																																																																																																							
31. [Symbol] [Text]	31. [Symbol] [Text]																																																																																																							
32. [Symbol] [Text]	32. [Symbol] [Text]																																																																																																							
33. [Symbol] [Text]	33. [Symbol] [Text]																																																																																																							
34. [Symbol] [Text]	34. [Symbol] [Text]																																																																																																							
35. [Symbol] [Text]	35. [Symbol] [Text]																																																																																																							
36. [Symbol] [Text]	36. [Symbol] [Text]																																																																																																							
37. [Symbol] [Text]	37. [Symbol] [Text]																																																																																																							
38. [Symbol] [Text]	38. [Symbol] [Text]																																																																																																							
39. [Symbol] [Text]	39. [Symbol] [Text]																																																																																																							
40. [Symbol] [Text]	40. [Symbol] [Text]																																																																																																							
41. [Symbol] [Text]	41. [Symbol] [Text]																																																																																																							
42. [Symbol] [Text]	42. [Symbol] [Text]																																																																																																							
43. [Symbol] [Text]	43. [Symbol] [Text]																																																																																																							
44. [Symbol] [Text]	44. [Symbol] [Text]																																																																																																							
45. [Symbol] [Text]	45. [Symbol] [Text]																																																																																																							
46. [Symbol] [Text]	46. [Symbol] [Text]																																																																																																							
47. [Symbol] [Text]	47. [Symbol] [Text]																																																																																																							
48. [Symbol] [Text]	48. [Symbol] [Text]																																																																																																							
49. [Symbol] [Text]	49. [Symbol] [Text]																																																																																																							
50. [Symbol] [Text]	50. [Symbol] [Text]																																																																																																							
CONTIENE:																																																																																																								
INSTALACIONES ELECTRICAS, HIDRAULICAS																																																																																																								
LOCALIZACIÓN:																																																																																																								
ESCALA	FECHA																																																																																																							
	02/12/2022																																																																																																							
NOTA	FIRMA TUTOR																																																																																																							
PLANCHA N°	PLANCHA N°																																																																																																							
12																																																																																																								
REVISION	PLANO N°	PLANCHA N°																																																																																																						
	P - 001	12																																																																																																						
		DE:																																																																																																						
		14																																																																																																						

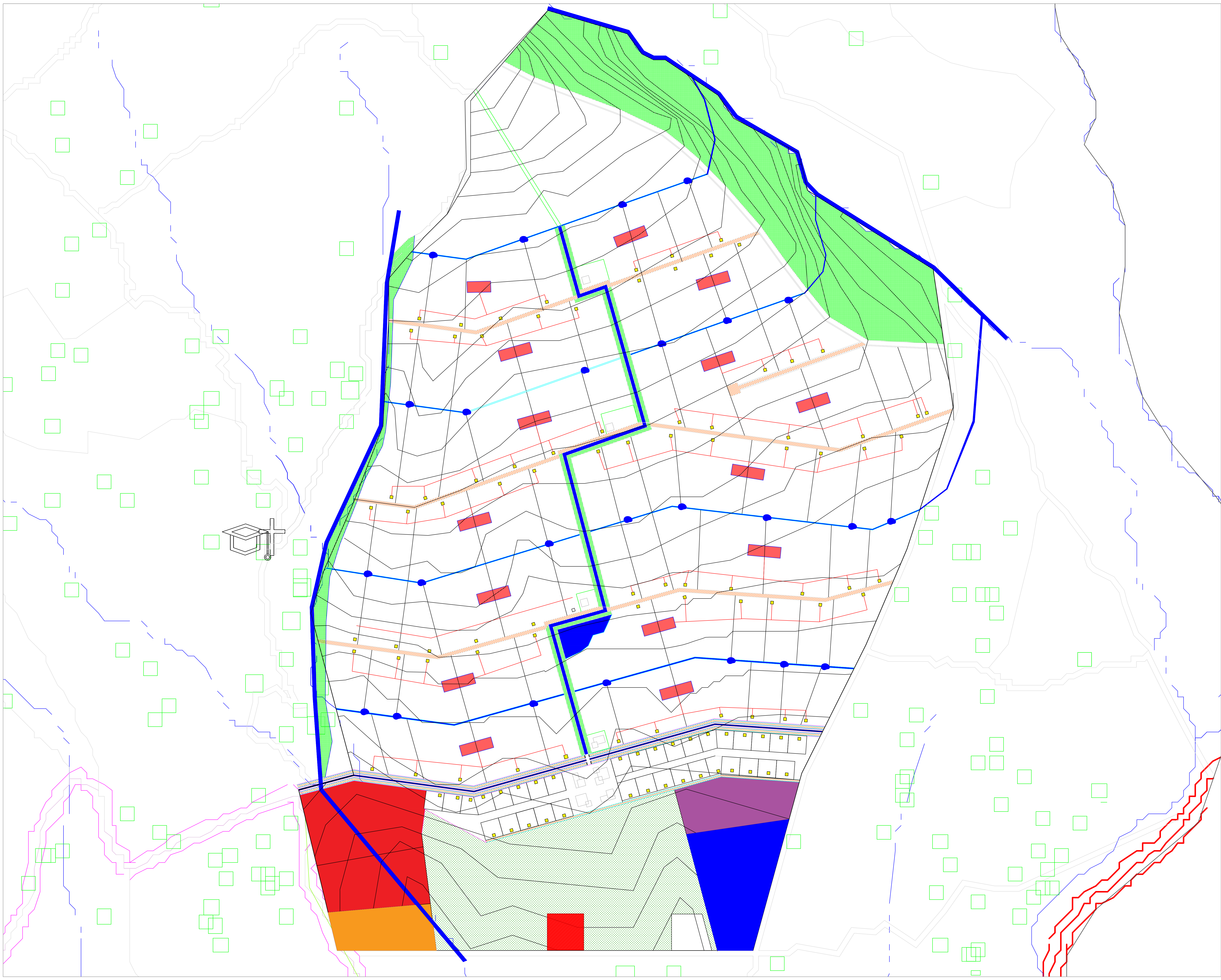

DE:	PLANO N°	REVISION
PLANO N°	13	DE:
FACULTAD DE ARQUITECTURA		
PROYECTO:		
MODELO AGROECOLÓGICO A PARTIR DE PROTOTIPOS SUSTENTABLES DE VIVIENDA RURAL PRODUCTIVA EN EL MUNICIPIO DE DUITAMA BOYACÁ		
CONVERSIONES		
CONTIENE:		
INSTALACION SUMINISTRO DE BIOGAS		
LOCALIZACIÓN:		
ESCALA	FECHA	
1:4000	02/12/2022	
NOTA	FIRMA TUTOR	
PLANCHA N°	PLANCHA N°	
13		
REVISION	PLANO N°	PLANCHA N°
	P - 002	13
		DE:
		14

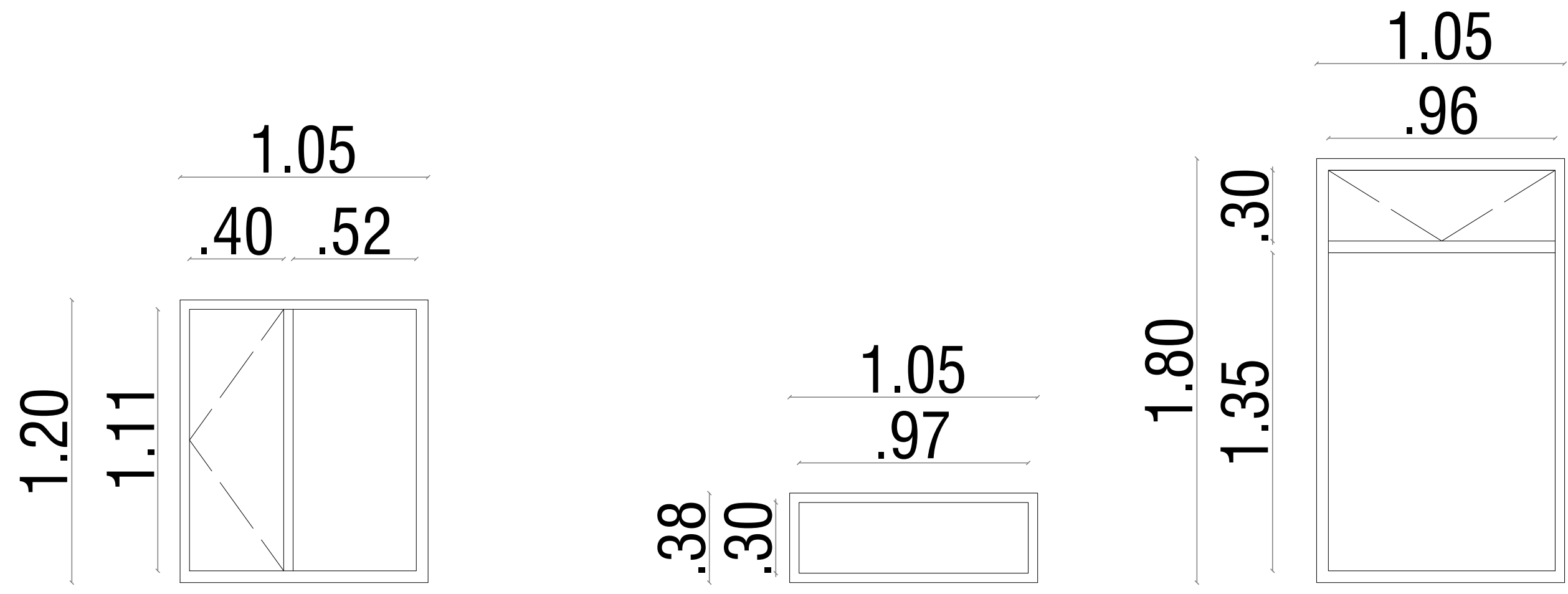

V - 1
A- 001

V - 2
A- 001

V - 3
A- 001

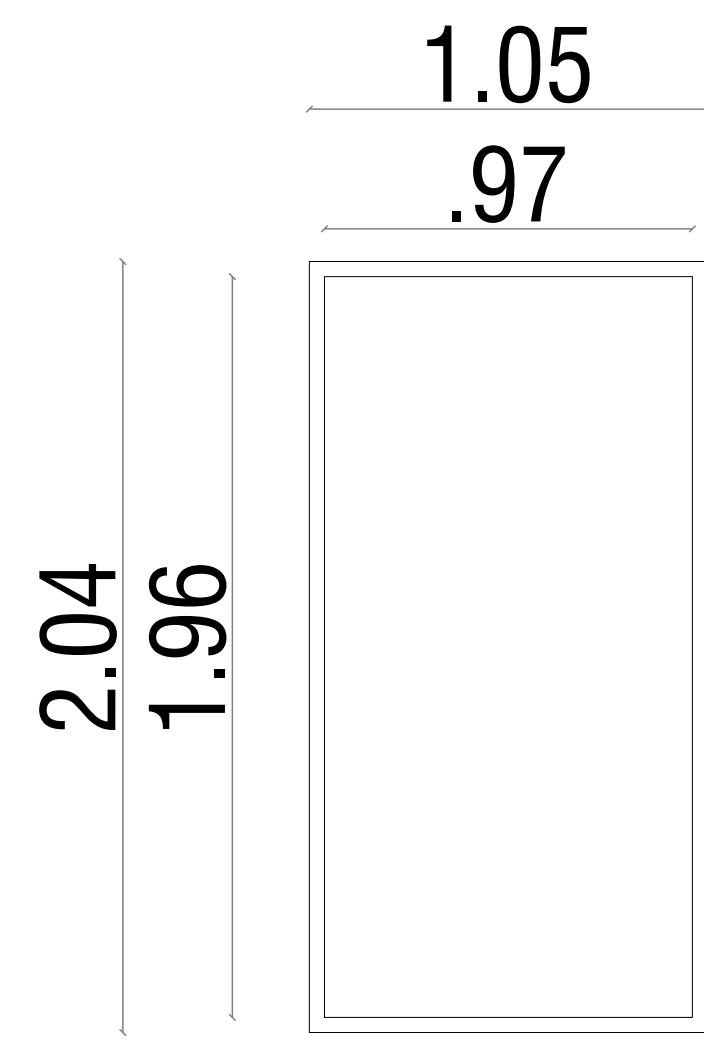

V - 4
A- 001

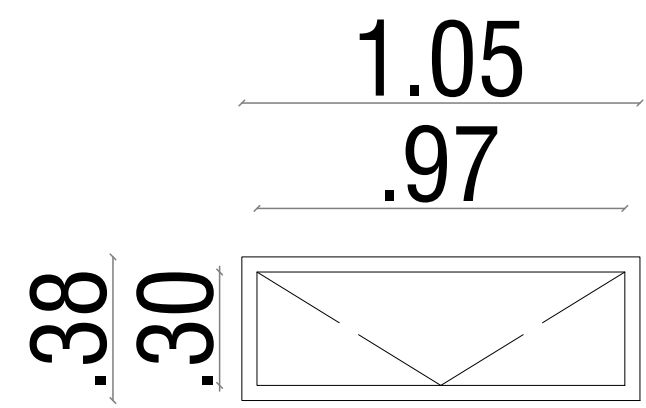

V - 5
A- 001

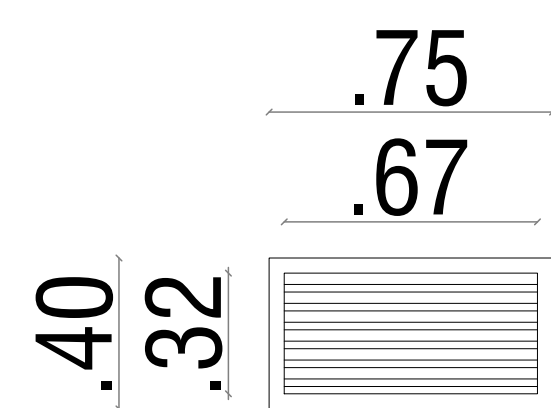

V - 6
A- 001

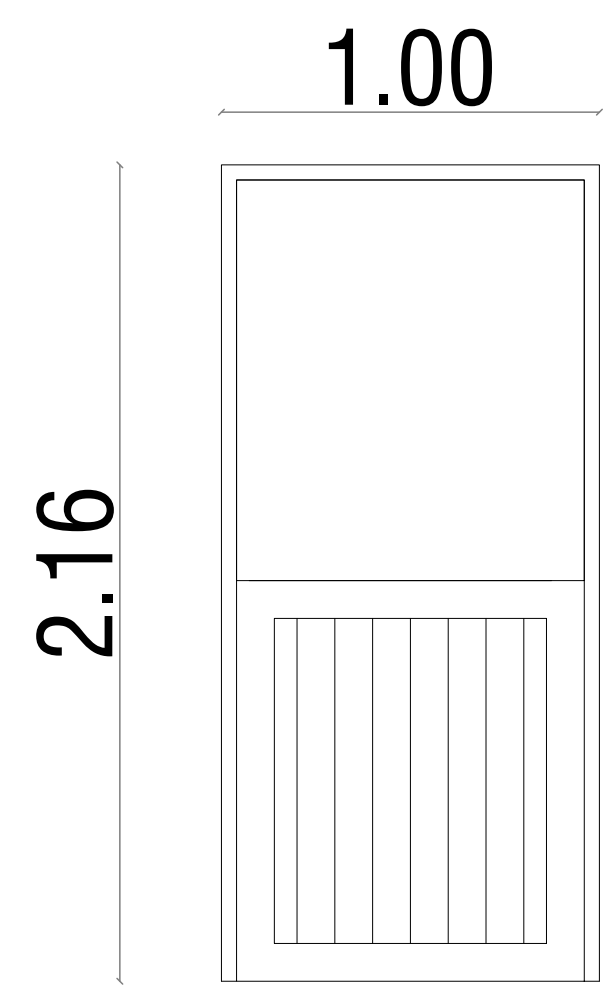

P - 1
D- 001

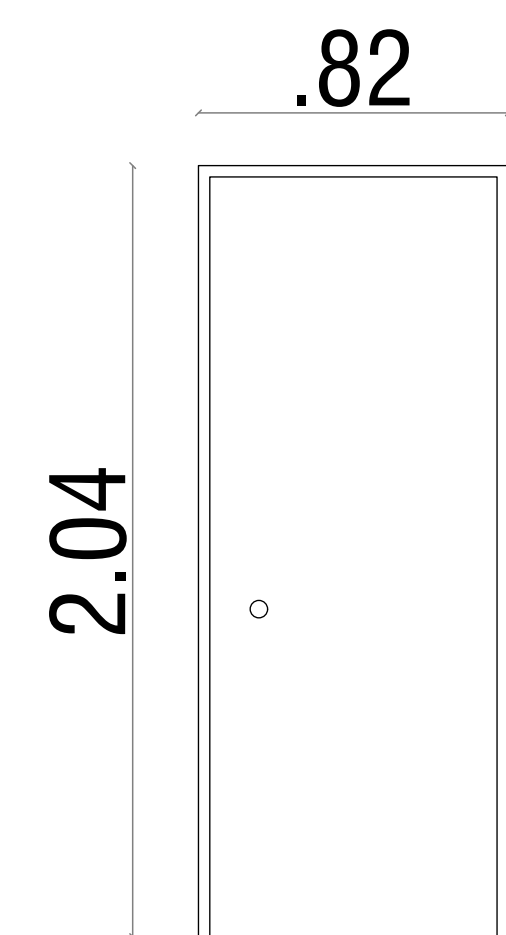

P - 2
D- 001

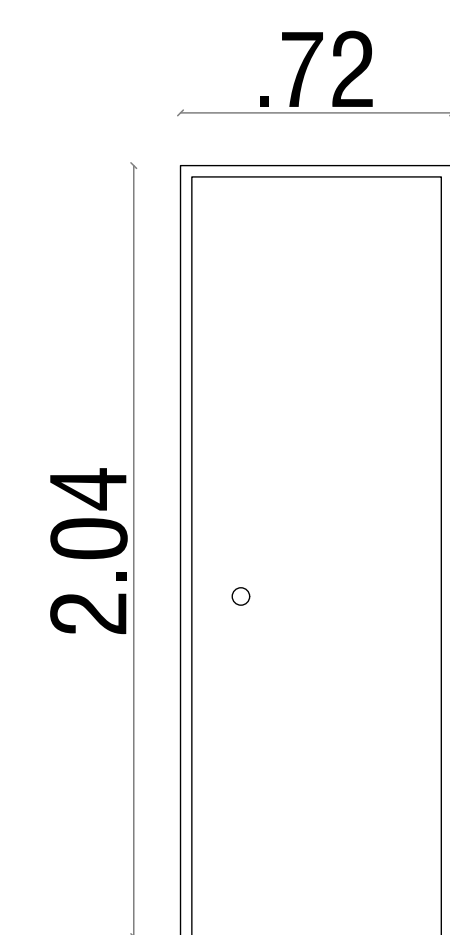

P - 3
D- 001

DE:	PLANO N°	REVISION
PLANCHA N°	PLANO N°	REVISION
FACULTAD DE ARQUITECTURA		
PROYECTO:		
MODELO AGROECOLÓGICO A PARTIR DE PROTOTIPOS SUSTENTABLES DE VIVIENDA RURAL PRODUCTIVA EN EL MUNICIPIO DE DUITAMA BOYACÁ		
CONVERSIONES		
CONTIENE:		
DETALLES		
LOCALIZACIÓN:		
ESCALA	FECHA	
1:20	02/12/2022	
NOTA	FIRMA TUTOR	
PLANCHA N°	PLANCHA N°	
14		
REVISION	PLANO N°	PLANCHA N°
	D - 001	14
		DE:
		14